

operator's
manual

STRATOS
ESCAPADE

1987

414 5982 00

model _____

V.I.N. _____

purchase date _____

warranty expiry date _____

To be completed by dealer at time of sale

DEALER IMPRINT AREA

AFTER SALES SERVICE
BOMBARDIER INC.
VALCOURT (QUEBEC)
CANADA, JOE 2LO

The following are trademarks of Bombardier Inc.

ALPINE®	FORMULA*	SAFARI*
BLIZZARD®	FUTURA®	SKANDIC®
BOMBARDIER®	GRAND PRIX SPECIAL®	SKI-DOO®
CARRY-BOOSE®	MIRAGE®	SONIC®
CITATION®	MOTO-SKI®	SPIRIT®
ELAN®	NORDIK®	STRATOS*
ELITE®	NUVIK®	T'NT®
ESCAPADE*	OLYMPIQUE®	TUNDRA*
EVEREST®	ROTAX®	





FOREWORD

The operator manual and the Snowmobile Safety Handbook have been prepared to acquaint the owner/operator or passenger of a new snowmobile with the various vehicle controls, maintenance and safe operating instructions. Each is indispensable for the proper use of the product, and should be kept with the vehicle at all times.

Should you have any questions pertaining to the warranty and its application, please consult the "Often Asked Questions" section of this manual, or your authorized dealer.

This manual uses the following symbols.

 **WARNING:** Identifies an instruction which, if not followed, could cause serious personal injuries including possibility of death.

 **CAUTION:** Denotes an instruction which, if not followed, could severely damage vehicle components.

 **NOTE:** Indicates supplementary information needed to fully complete an instruction.

Although the mere reading of such information does not eliminate the hazard, your understanding of the information will promote its correct use.

The information, illustrations and components/system descriptions contained in this manual are correct at time of publication. Bombardier Inc. however, maintains a policy of continuous improvement of its products without imposing upon itself any obligation to install them on products previously manufactured.

Bombardier Inc. reserves the right at any time to discontinue or change specifications, designs, features, models or equipment without incurring obligation.

The illustrations show the typical construction of the different assemblies and, in all cases, may not reproduce the full detail or exact shape of the parts shown, however, they represent parts which have the same or a similar function.

Most specifications are given in both metric and customary units. Where precise accuracy is not required, some conversions are rounded to even numbers for easier use.

A shop manual can be obtained for complete service, maintenance and repair information.

 **WARNING:** The engines and the corresponding components identified in this manual should not be utilized on product(s) other than those mentioned on the cover page of this manual.

 **CAUTION:** Several components of this vehicle are built with parts dimensioned in the metric system. Most fasteners are metric and must not be replaced by customary fasteners or vice versa. Mismatched or incorrect fasteners could cause damage to the vehicle or possible personal injury.

SAFETY MEASURES

Observe the following precautions:

- Throttle mechanism should be checked for free movement before starting engine.
- The snowmobile engine can be stopped by activating the emergency cut-out or tether switches or turning off the key.
- Clean and check operation of the headlight tail light and brake light.
- Engine should be running only when belt guard and/or pulley guard is secured in place.
- Never run the engine without drive belt installed. Running an unloaded engine can prove to be dangerous.
- Never run the engine when the track is raised off the ground.
- It can be dangerous to run engine with the hood removed.
- Gasoline is flammable and explosive under certain conditions. Always manipulate in a well ventilated area. Do not smoke or allow open flames or sparks in the vicinity. If gasoline fumes are noticed while driving, the cause should be determined and corrected without delay.
- Maintain your vehicle in top mechanical condition at all times.
- Your snowmobile is not designed to be driven or operated on black top, bare earth, or other abrasive surfaces. On such surfaces abnormal and excessive wear of critical parts is inevitable.
- Your snowmobile is not designed to be operated on public streets, road or highways. In most States and Provinces, it is considered an illegal operation.
- Installation of other than standard equipment, including ski-spreaders, bumpers, pack racks, etc., could severely affect the stability and safety of your vehicle. Avoid adding on accessories that alter the basic vehicle configuration.
- Whenever the vehicle is parked outdoors, overnight or for a long period, it is suggested to protect it against the inclemency of the weather with a snowmobile cover.
- Do not lubricate throttle and/or brake cables and housings.
- Only perform procedures as detailed in this manual. Unless otherwise specified, engine should be turned OFF for all lubrication and maintenance procedures.
- The Stratos model is designed for the driver only. No provisions have been made for a passenger.
- Should removal of a nylon lock nut be required when undergoing repairs/disassembly, always replace by new ones. Tighten as specified in the applicable Shop Manual.

PLEASE READ AND UNDERSTAND ALL WARNINGS AND CAUTIONS IN THIS MANUAL AND ON THE VEHICLE.

THIS MANUAL SHOULD REMAIN WITH THE VEHICLE AT THE TIME OF RESALE.

INDEX

THE 1987 "LIMITED WARRANTY"	4
OFTEN ASKED QUESTIONS	6
LISTING OF AREA DISTRIBUTORS	8
HOW TO IDENTIFY YOUR SNOWMOBILE	9
CONTROLS/INSTRUMENTS	
Throttle lever, brake lever, ignition switch, headlamp dimmer switch, emergency cut-out switch, tether cut-out switch, rewind starter handle, primer, adjustable steering handle, speedometer, tachometer, electric fuel level gauge, injection oil level pilot lamp, high beam pilot lamp, hot grip switch, tank cap, hood opening, seat belt, tool box, fuse holders	10
BREAK-IN PERIOD	
Engine and belt break-in, 10 hour-inspection, inspection check list	14
GAS & OIL	
Recommended gasoline, recommended oil, oil injection system	16
PRE-START CHECK	
Check points	16
STARTING PROCEDURE	
Manual starting, electric starting, before riding, emergency starting	17
LUBRICATION	
Frequency, steering mechanism, drive axle, slide suspension, chaincase oil level, oil injection system	19
MAINTENANCE	
Maintenance chart, belt guard removal and installation, drive belt removal, drive belt condition, new drive belt, brake condition, brake adjustment, spark plugs, battery, suspension condition, stopper strap condition, suspension adjustment, stopper strap, track condition, track tension and alignment, drive pulley, steering mechanism, steering adjustment, muffler attachments, engine head nuts, engine mount nuts, carburetor adjustment, oil injection system, fan belt, headlamp beam aiming, bulb replacement, general inspection	22
STORAGE	
Track, suspension, skis, controls, chaincase, drive pulley, engine and primer lubrication, gas tank and carburetor, battery, chassis, general inspection, suspension stopper strap	34
PRE-SEASON PREPARATION	
Pre-season preparation chart	38
TROUBLE SHOOTING GUIDE	39
TOOLS	41
SPECIFICATIONS	42
WIRING DIAGRAMS	44
SI INFORMATION GUIDE	46

THE 1987 SNOWMOBILE LIMITED WARRANTY

1 - PERIOD

BOMBARDIER® INC. as manufacturer, warrants FROM THE DATE OF FIRST CONSUMER SALES, every 1987 BOMBARDIER snowmobile, sold as NEW AND UNUSED, and predelivered by an authorized BOMBARDIER dealer for a period of:

- 12 consecutive months.

2 - WHAT BOMBARDIER WILL DO

BOMBARDIER will repair and/or replace, at its option, components defective in material and/or workmanship (under normal use and service,) with a genuine BOMBARDIER component without charge for parts or labour, at any authorized BOMBARDIER dealer during said warranty period.

3 - CONDITION TO HAVE WARRANTY WORK PERFORMED

Present to the servicing dealer, the hard copy of the BOMBARDIER Warranty Registration card or proof of purchase received by the customer from the selling dealer at time of purchase.

4 - WARRANTY TRANSFER

This warranty is transferable to subsequent owner(s) for remainder of warranty period from original date of sale.

5 - EXCLUSIONS - ARE NOT WARRANTED

- Normal wear on all items such as, but not limited to:
 - drive belts
 - bulbs
 - slider shoes
 - runners on skis
 - spark plugs
- Replacement parts and/or accessories which are not genuine BOMBARDIER parts and/or accessories.
- Damage resulting from installation of parts other than genuine BOMBARDIER parts.
- Damage caused by failure to provide proper maintenance as detailed in the Operator's Manual. The labour, parts and lubricants costs of all maintenance services, including tune-ups and adjustments will be charged to the owner.
- Vehicles designed and/or used for racing purposes.
- All optional accessories installed on the vehicle.
(The normal warranty policy for parts and accessories, if any, applies).
- Damage resulting from accident, fire or other casualty, misuse, abuse or neglect.
- Damage resulting from operation of the snowmobile on surfaces other than snow.
- Damage resulting from modification to the snowmobile not approved in writing by BOMBARDIER.

-
- Losses incurred by the snowmobile owner other than parts and labour, such as, but not limited to, transportation, towing, telephone calls, taxis, or any other incidental or consequential damage.

6 - BATTERY WARRANTY:

- 12 consecutive months. (Pro-rated)

100% warranty coverage will start on the date the snowmobile was purchased and run to the following April 30th. The remainder of the 12 month period will be pro-rated as follows:

- 50% from April 30th to December 1st.
- 40% from December 1st to December 31st.
- 30% from January 1st to end of warranty.

7 - EXPRESSED OR IMPLIED WARRANTIES

This warranty gives you specific rights, and you may also have other legal rights which may vary from state to state, or province to province. Where applicable this warranty is expressly in lieu of all other expressed or implied warranties of BOMBARDIER, its distributors and the selling dealer, including any warranty of merchantability or fitness for any particular purpose; otherwise the implied warranty is limited to the duration of this warranty. However, some states or provinces do not allow limitations on how long an implied warranty lasts, so the above limitation may not apply.

Neither the distributor, the selling dealer, nor any other person has been authorized to make any affirmation, representation or warranty other than those contained in this warranty, and if made, such affirmation, representation or warranty shall not be enforceable against BOMBARDIER or any other person.

Some states or provinces do not allow the exclusion or limitation of incidental or consequential damages, so the above limitation or exclusion may not apply.

BOMBARDIER INC. reserves the right to modify its warranty policy at any time, being understood that such modification will not alter the warranty conditions applicable to vehicles sold while the above warranty is in effect.

8 - CONSUMER ASSISTANCE

If a servicing problem or other difficulty occurs, we suggest the following:

1. Try to solve the problem at the dealership with the Service Manager or Owner.
2. If this fails, contact your area distributor listed in the Operator's Manual.
3. Then if your grievance still remains unsolved, you may write to us:

Bombardier Inc.
Service Department
Recreational Products Division
Valcourt (Quebec), Canada, JOE 2LO

February 1986
Bombardier Inc.
Valcourt (Quebec), Canada, JOE 2LO
© * Trademarks of Bombardier Inc.

OFTEN ASKED QUESTIONS

Q: Why must my snowmobile be registered? After all I do have my original invoice as proof of when I purchased my snowmobile.

A: Your warranty is valid at any authorized dealer of the product. Your registration is the key element in providing the servicing dealer with the necessary data to complete warranty claim forms. This information is also used to notify owners in the event of a safety recall.

Q: Who should send the registration card to Bombardier Inc.?

A: The dealer. However, it is important that the customer make sure that it has been sent. The company might contact you should your vehicle be recalled or in case of a particular warranty campaign.

Q: I bought my snowmobile in O'King County but I snowmobile in Washington County. Can the dealer in Washington County accept to perform warranty work on my snowmobile?

A: Yes, any authorized dealer in North America can perform warranty repairs, providing the customer warranty registration card is presented.

Q: Where can I find information on the lubrication and maintenance of my snowmobile?

A: In this Operator Manual provided with the vehicle at the time of first sale.

Q: Will the entire warranty be void or cancelled, if I do not operate or maintain my new snowmobile exactly as specified in the Operator's Manual?

A: The warranty of the new snowmobile cannot be "Voided" or "Cancelled". However, if a particular failure is caused by operation or maintenance other than is shown in the Operator Manual, THAT failure may not be covered under warranty. This includes service work performed by the customer, especially the critical adjustments to ignition, timing, carburation and oil injection/or oil mixture.

Q: Would you give some examples of abnormal use or strain, neglect or abuse?

A: These terms are general and overlap each other in areas. Some specific examples may include: running the machine out of oil, chain failure caused by a lack of lubrication, operating the machine with a broken or damaged part which causes another part to fail, and so on. If you have any specific questions on operation or maintenance, please contact your dealer for advice.

Q: What costs are my responsibility during the warranty period?

A: The customer's responsibility includes all costs of normal maintenance services, non-warranty repairs, accidents and collision damage, as well as oils, and spark plugs, and incidental or consequential damages costs as explained in the warranty.

Q: Are "Genuine" Bombardier replacement parts used in warranty repairs covered by warranty?

A: Yes. When installed by an authorized dealer, any "genuine" Bombardier part used in warranty repairs assumes the remaining warranty that exists on the machine.

Q: If I sell my snowmobile within the warranty period, will the new owner qualify for the balance of the warranty?

A: Yes, provided the unit has already been registered with the manufacturer. Note that the change of ownership card in this manual should be completed and sent to Bombardier Inc.

Q: How can I receive the best owner assistance?

A: The satisfaction and goodwill of the owners of Bombardier products are of primary concern to your dealer and Bombardier Inc. Normally, any problems that arise in connection with the sales transaction or the operation of your snowmobile will be handled by your Dealers Sales or Service Departments. It is recognized, however, that despite the best intentions of everyone concerned, misunderstandings will sometimes occur. If you have a problem that has not been handled to your satisfaction through normal channels, we suggest that you discuss your problem with a member of dealership management. Frequently, complaints are the result of a breakdown in communications and can quickly be resolved by a member of the dealership management. If the problem already has been reviewed with the Sales Manager or Service Manager, contact the Dealer himself or the General Manager.

LISTING OF AREA DISTRIBUTORS

CANADIAN DISTRIBUTORS

Quebec Branch
1350 Nobel
Boucherville (Quebec) J4B 1A1
(514) 655-6121
Province of Quebec

Ontario Branch
230 Bayview Drive
Barrie (Ontario) L4N 4Y8
(705) 728-8600
Province of Ontario

Technical office
P.O. Box 7060
Riverview (New Brunswick) E1B 1V0
(506) 386-6117
Atlantic Region

BROOKS EQUIPMENT LIMITED
1616 King, Edward Street
P.O. Box 985
Winnipeg (Manitoba) R3C 2V8
(204) 633-7247
**British Columbia, Manitoba, Saskatchewan,
Alberta, Yukon**

CHARLES R. BELL LIMITED
Newfoundland, Labrador
Offices
- Riverside Drive
P.O. Box 1050
Corner Brook (Newfoundland) A2H 6J3
(709) 634-3533
- 81 Kenmount Road
P.O. Box 8127
St-John's (Newfoundland) A1B 3N1
(709) 722-6700

HUDSON'S BAY CO. LTD.
165 Hymus Blvd
Pointe-Claire (Quebec) H9R 1G2
(514) 697-8500
**North-West Territories, Franklin District &
Keewatin**

AMERICAN DISTRIBUTORS

BOMBARDIER CORPORATION
All States (excluding Alaska)

SERVICE OFFICES
- East Main Street Road
Malone, New York 12953
(518) 483-4411

Technical office
(506) 386-6117

- 4505 West Superior Street
P.O. Box 6106
Duluth, Minnesota 55816-016
(218) 628-2881

- P.O. Box 1569
Idaho Falls, Idaho, 83403
(208) 529-9510

NATIONAL SALES OFFICE
- O'Hare Lake Plaza
2350 Devon Avenue
Suite 150
Des Plaines, Illinois 60018
(312) 298-9540

MILLER EQUIPMENT AND RECREATIONAL
CENTER
1049 Whitney Road
Anchorage, Alaska 99501
(907) 274-9513
Alaska

HOW TO IDENTIFY YOUR SNOWMOBILE

The main components of your snowmobile (engine, track and frame) are identified by different serial numbers. It may sometimes become necessary to locate these numbers for warranty purposes or to trace your snowmobile in the event of theft.

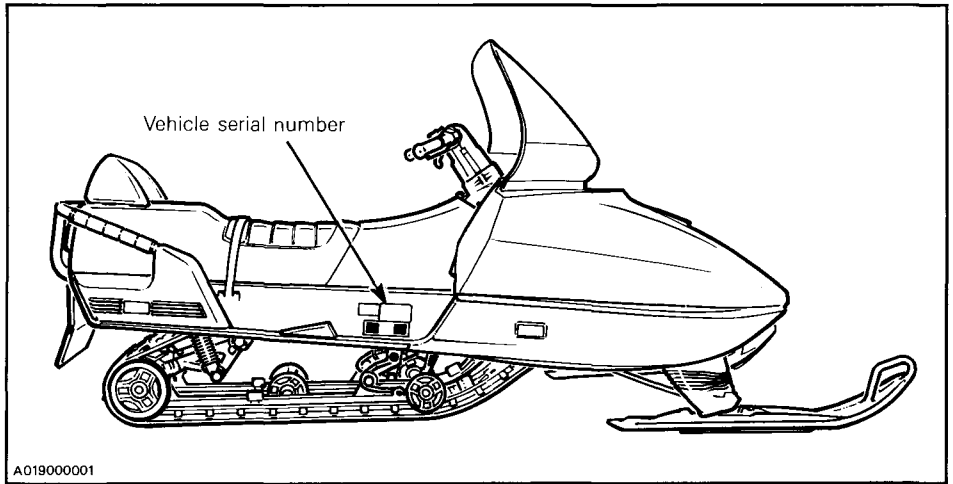
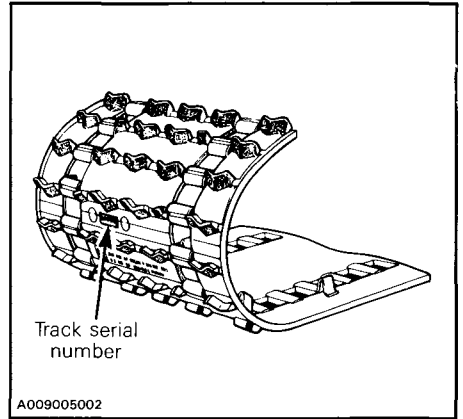
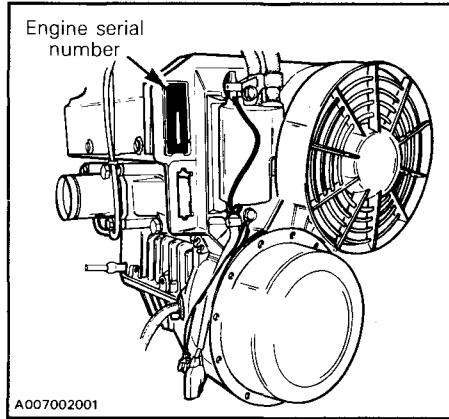

Vehicle serial number meaning:

0000 00000

Model no

Vehicle no

A000000013

NOTE: We strongly recommend that you take note of all the serial numbers on your vehicle and supply them to your insurance company. It will surely help in the event a snowmobile is stolen.

CONTROLS/INSTRUMENTS

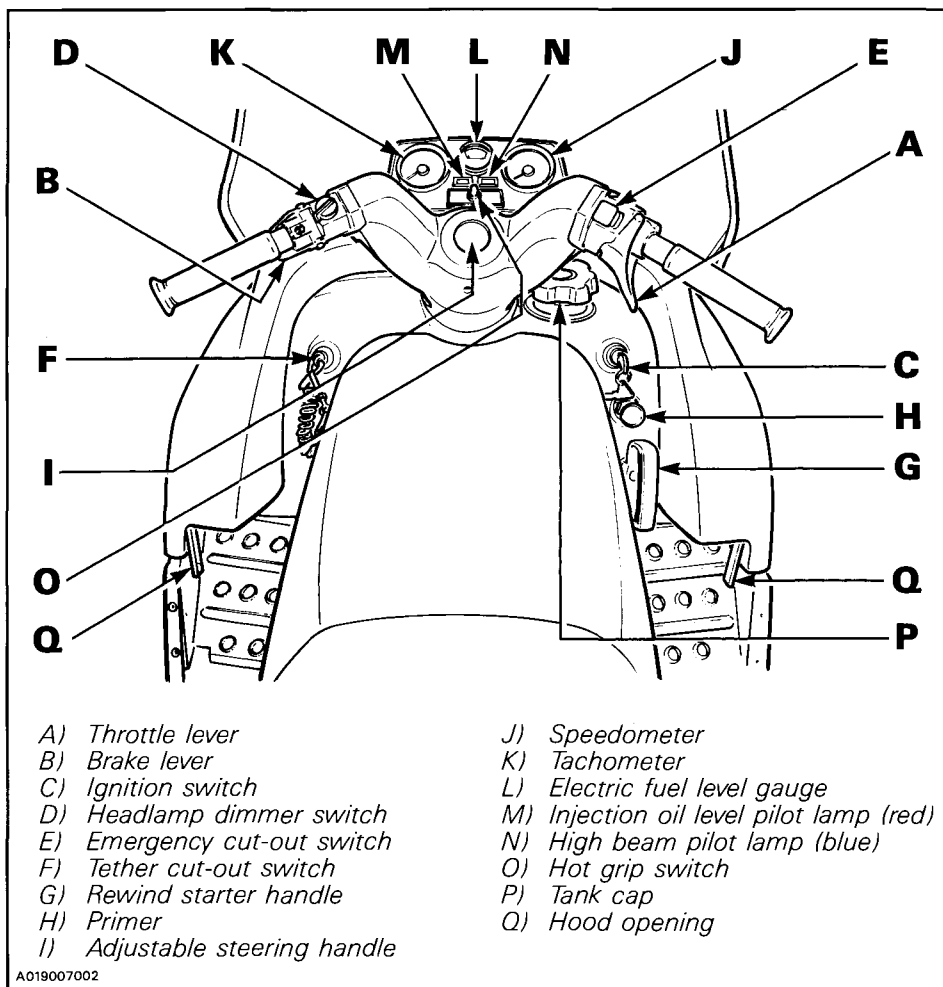

A) Throttle Lever

Located on the right side of handlebar. When compressed, it controls the engine speed and the engagement of the transmission. When released, engine speed returns automatically to idle.

B) Brake Lever

Located on the left side of handlebar. When compressed, the brake is applied. When released, it automatically returns to its original position. Braking effect is proportionate to the pressure applied on the lever and to the type of terrain and its snow coverage.

C) Ignition Switch

The lights are automatically ON whenever the engine is running.

Manual Starting

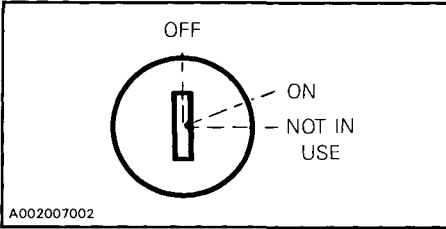

Key operated, 3 position switch. To start the engine, first turn the key clockwise to ON position. To stop the engine, turn the key counter-clockwise to OFF position.

The 3rd position is not in use.

Electric Starting

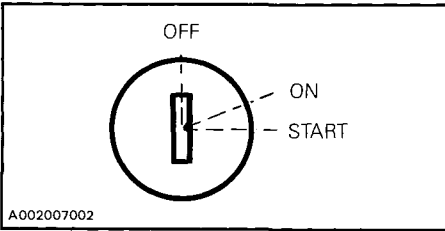

Key, operated, 3 position switch. To start engine, turn key fully clockwise to START position and hold. Return key to ON position immediately when engine has started. To stop engine, turn key counter-clockwise to OFF position.

CAUTION: Holding key in START position when engine has started could damage starter mechanism.

D) Headlamp Dimmer Switch

The dimmer switch allows correct selection of headlamp beam. To obtain high or low beam simply flick switch.

E) Emergency Cut-Out Switch

To stop the engine in an emergency, push the button to the lower off position and simultaneously apply the brakes. To start engine, button must be at the upper on position.

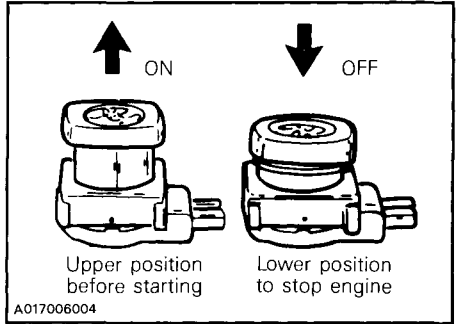

The driver of this vehicle should familiarize himself with the function of this device by using it several times on first outing. Thereby being mentally prepared for emergency situations requiring its use.

WARNING: For safety reasons, the emergency cut-out switch is easily accessible; be careful not to operate it inadvertently.

WARNING: If the switch has been used in an emergency situation the source of malfunction should be determined and corrected before restarting engine.

F) Tether Cut-Out Switch

Attach tether cord to wrist or other convenient location of the driver's clothing. Snap tether cut-out cap over receptacle before starting engine.

If emergency engine "shut off" is required, completely pull cap from safety switch and engine power will be automatically shut "off".

 **NOTE:** The cap must be installed on the safety switch at all times in order to operate the vehicle.

 **WARNING:** If the switch is used in an emergency situation the source of malfunction should be determined and corrected before restarting engine.

G) Rewind Starter Handle

Auto rewind type located on right hand side of vehicle. To engage mechanism, pull handle.

H) Primer

Pull and push button (2-3 times) to activate primer. The primer should always be used for cold engine starts. When engine is warm however, it is not necessary to use primer when starting.

I) Adjustable Steering Handle

- Remove steering pad.
- Loosen the four (4) retaining screws.
- Adjust the handle to the desired position.

 **WARNING:** Do not adjust too high as the brake lever may contact the windshield when turning.

- Lock the steering handle in place by tightening the four (4) retaining screws to 26 N•m (19 lbf•ft).
- Reinstall steering pad.

J) Speedometer

The speedometer is linked directly to the drive axle. Direct-reading dial indicates the speed of the vehicle. Odometer records the total distance travelled in kilometers.

K) Tachometer

The tachometer registers the impulses of magneto. Direct-reading dial indicates the number of revolutions per minute (RPM) of the engine.

 **CAUTION:** The tachometer is protected by a fuse, if tachometer stops operating check fuse condition and if necessary replace. The fuse is 0.1 amp. Do not use a higher rated fuse as this can cause severe damage to the tachometer.

L) Electric Fuel Level Gauge

The electric fuel gauge is located in the dashboard and allows driver to observe the fuel level while riding the snowmobile.

M) Injection Oil Level Pilot Lamp (Red)

Will light up when injection oil level is low. Check level and replenish as soon as possible.

 **CAUTION:** Do not run engine until it is out of oil. Serious engine damage will occur.

Whenever brake lever is compressed, oil level pilot lamp should light up. If not, replace lamp.

N) High Beam Pilot Lamp (Blue)

Lights up when headlamp is on high beam.

O) Hot Grip Switch

The 3 position toggle switch is located in dashboard underneath pilot lamps. Select the desired position to keep hands at a comfortable temperature.

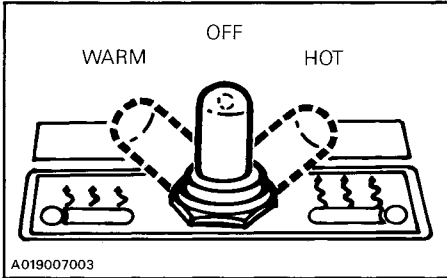

P) Tank Cap

Unscrew to fill up tank then fully tighten.

◆ **WARNING:** Never use a lit match or open flame to check fuel level.

Q) Hood Opening

Pull down the latches to unlock the hood from the anchor.

○ **NOTE:** Always lift hood gently up until stopped by restraining device.

◆ **WARNING:** It is dangerous to run an engine with the hood open, unfastened or removed.

Seat Belt

(Escapade only)

Located on middle of seat. Provide a grip for the rear passenger.

Tool Box

Located under the hood. To gain access, tilt hood. Ideal location for spare plugs, rope, first aid kit, flashlight, etc.

Fuse Holders

Starter (electric starting)

Starting system is protected with a 30 amperes rated fuse. Fuse holder is located near the starter. If starter does not operate, check fuse condition and if necessary replace.

Tachometer

The tachometer is protected with 0.1 ampere rated fuse. Fuse holder is located under the hood behind the tachometer. If it stops operating, check fuse condition and replace if necessary.

BREAK-IN PERIOD

Engine

With Bombardier-Rotax snowmobile engines, a break-in period is required before running the vehicle at full throttle. Engine's manufacturer recommendation is 10 to 15 operating hours. During this period, maximum throttle should not exceed 3/4, however, brief full acceleration and speed variations contribute to a good break-in. Continued wide open throttle accelerations, prolonged cruising speeds, and lugging are detrimental during the break-in period.

 **NOTE:** To assure additional protection during the initial engine break-in, 500 ml (18 imp. oz) of BLIZZARD OIL should be added to gas for the first full gas tank filling.

 **CAUTION:** Remove and clean spark plugs after engine break-in.

Belt

A new drive belt requires a break-in period of 25 km (15 miles).

10-Hour Inspection

As with any precision piece of mechanical equipment, we suggest that after the first 10 hours of operation or 30 days after the purchase, whichever comes first, your vehicle be checked by your dealer. This inspection will give you the opportunity to discuss the unanswered questions you may have encountered during the first hours of operation. Remember that it is easier to remedy at this time than to allow the snowmobile to operate until a possible failure occurs.

The 10 hour inspection is at the expense of the vehicle owner.

10-HOUR INSPECTION CHECKLIST	✓
Engine timing	
Fan belt tension	
Spark plugs condition: (Remove and clean)	
Carburetor adjustment	
Oil injection pump adjustment	
Engine head nuts	
Engine mount nuts	
Muffler attachment	
Chaincase oil level	
Injection system oil level	
Brake operation and lining condition	
Ski alignment (runner condition)	
Handlebar bolts, retorque to 26 N•m (19 lbf•ft)	
Pulley alignment and drive belt condition	
Track condition, tension and alignment	
Lubrication (steering, suspension, drive axle)	
Electrical wiring (loose connections, stripped wires, damaged insulation), tighten all loose bolts, nuts and linkage	
Operation of lighting system (HI / LO beam, brake light, etc.), test operation of emergency cut-out switch and tether switch	
Battery electrolyte level (electric starting)	

We recommend that you have your dealer sign this inspection list.

Date of 10 hour inspection

Dealer signature

GAS & OIL

Recommended Gasoline

Use regular leaded or unleaded gasoline available from all service stations.

▼ **CAUTION:** Never experiment with different fuel, never use naphtha, methanol, gasohol or similar products.

◆ **WARNING:** Never "top up" the gas tank before placing the vehicle in a warm area. At certain temperatures, gasoline will expand and overflow. Always wipe off any gasoline spillage from the snowmobile.

Recommended Oil

Use "Bombardier Snowmobile Injection Oil" (P/N 496 0133 00 - 1 liter) available from the dealer. This type of oil will flow at temperatures as low as minus 40°C (-40°F).

If "Bombardier Snowmobile Injection Oil" is unavailable, substitute with BLIZZARD OIL. (P/N 496 0135 00 - 500 ml).

▼ **CAUTION:** Never use outboard or straight mineral oils.

Oil Injection System

Always maintain a sufficient amount of Bombardier Snowmobile injection oil in the injection oil tank.

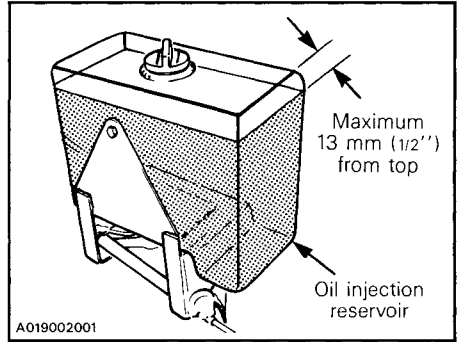

▼ **CAUTION:** Check level and refill every time you refuel. Do not overfill.

○ **NOTE:** To assure additional protection during the initial engine break-in, 500 ml (18 imp. oz) of BLIZZARD OIL should be added to gas for the first full gas tank filling.

PRE-START CHECK

Check Points

- ACTIVATE THE THROTTLE CONTROL LEVER SEVERAL TIMES to check that it operates easily and smoothly. The throttle control lever must return to idle position when released.
- Check that the skis and the track are not frozen to the ground or snow surface and that steering operates freely.
- Activate the brake control lever and make sure the brake fully applies before the brake control lever touches the handlebar grip.

- Check injection oil level.
- Check gas level.
- Verify that the path ahead of the vehicle is clear of bystanders and obstacles.

◆ **WARNING:** Only start the snowmobile once all components are checked and functioning properly.

STARTING PROCEDURE

Test throttle control lever.

Check that the emergency cut-out switch is in the ON position.

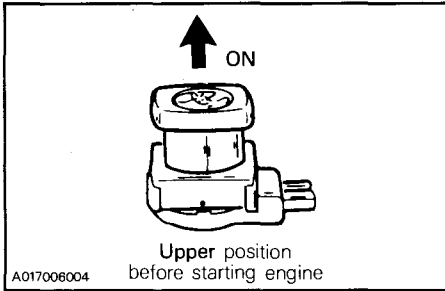

Ensure the tether cut-out cap is in position and that the cord is attached to the clothing.

Activate the primer (2 or 3 times).

○ **NOTE:** The use of the primer is not necessary when the engine is warm.

Manual Starting

Insert the key in the ignition and turn to ON position.

Grasp manual starter handle firmly and pull slowly until a resistance is felt then pull vigorously. Slowly release the rewind starter handle.

◆ **WARNING:** Do not apply throttle while starting.

Electric Starting

▼ **CAUTION:** Never operate your snowmobile with the battery removed or disconnected. Since the battery reduces voltage fluctuations, operating vehicle without battery might cause instrument or bulb failure.

Turn ignition key clockwise until starter engages.

▼ **CAUTION:** To avoid starter overheating, the cranking period should never exceed 30 seconds and a rest period should be observed between the cranking cycles to let starter cool down.

Release key immediately when engine has started. If engine does not start on first try, key must be turned fully back to OFF each time.

◆ **WARNING:** Do not apply throttle while starting.

○ **NOTE:** If for some reason the vehicle cannot be started electrically, place ignition key to ON position and start engine manually.

Before Riding

Check operation of the emergency cut-out switch, and tether switch. Restart engine.

◆ **WARNING:** If engine does not shut-off when applying the emergency cut-out switch and or when pulling the tether cut-out cap, stop the engine by turning off the ignition key. Do not operate the vehicle further, see the dealer.

Allow the engine to warm before operating at full throttle.

Emergency Starting

Should the rewind starter rope fray and break, the engine can be started with an emergency starter rope supplied with the tool kit.

○ **NOTE:** The spark plug socket can be used as an emergency starter grip.

◆ **WARNING:** Do not wind starting rope around your hand. Hold rope by the handle only.

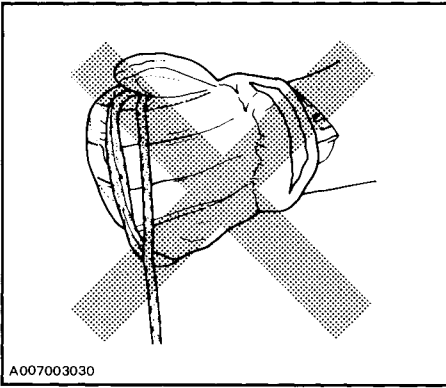

◆ **WARNING:** Do not start the vehicle by the drive pulley unless it is a true emergency situation. Have the vehicle repaired as soon as possible.

Attach emergency rope to any available handle and to the starter clip supplied in the tool box. Wind the rope tightly around drive pulley.

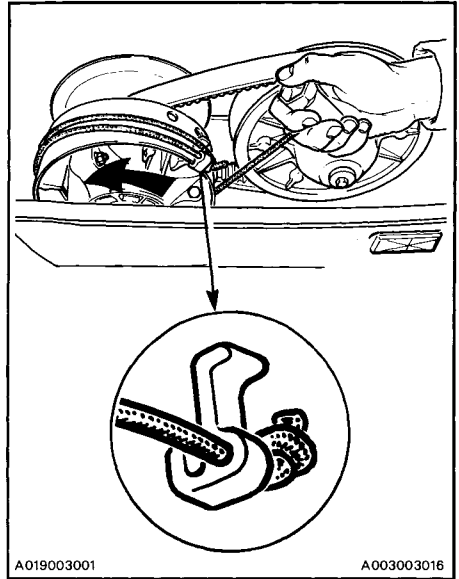

Start engine as per usual manual starting.

◆ **WARNING:** When starting the vehicle in an emergency situation by the drive pulley, do not reinstall the belt guard.

LUBRICATION

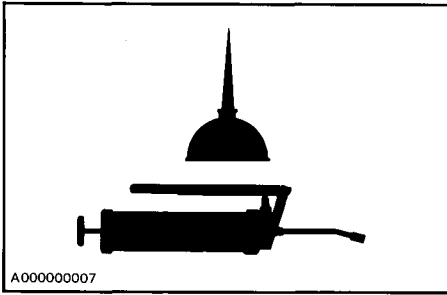

Frequency

Routine maintenance is necessary for all mechanized products, and the snowmobile is no exception. A weekly vehicle inspection contributes to the life span of the snowmobile as well as retains safe and dependable operation.

It is recommended that the steering system and suspension be lubricated monthly or every 40 hours of operation. If the vehicle is operated in wet snow or in severe conditions these items should be lubricated more frequently.

○ **NOTE:** When lubricating grease fittings, grease until grease appears at joints. Always use low temperature grease (P/N 413 7061 00).

◆ **WARNING:** Only perform such procedures as detailed in this manual. It is recommended that dealer assistance be periodically obtained on other components/systems not covered in this manual. Unless otherwise specified, engine should be turned OFF for all lubrication and maintenance procedures.

◆ **WARNING:** Do not lubricate throttle and/or brake cables and housings.

Steering Mechanism

Oil ball joints and steering column bushings.

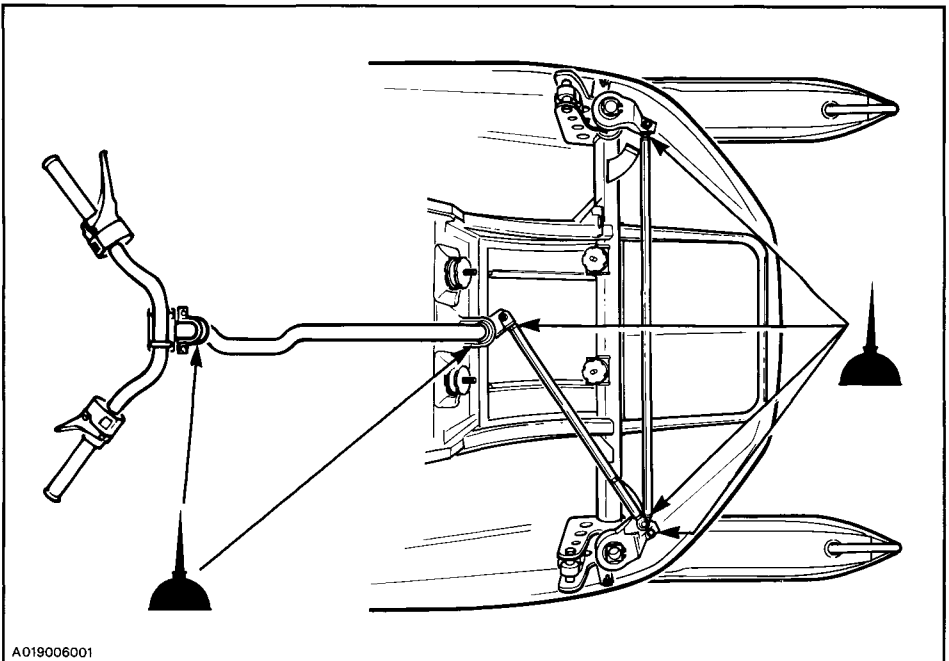

The following lubrication points have to be performed on LH & RH sides:

- Lubricate ski leg shaft from inside of hood.

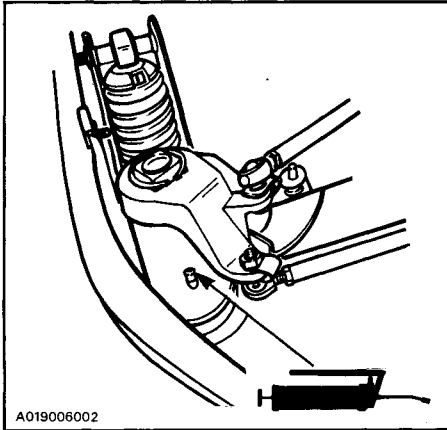

- Unhook ski leg boot spring and raise boot to gain access.
- Lubricate ski pivot and ski leg lower bushing.

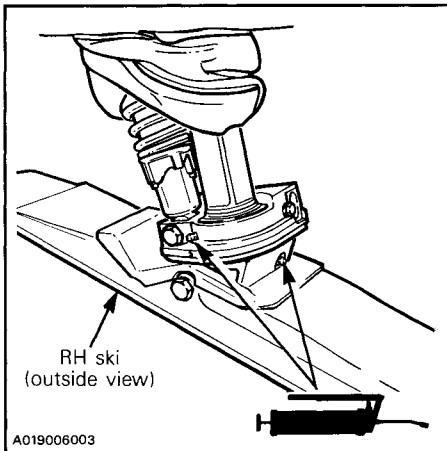

- Reinstall boot and secure the spring.
- Coat stabilizer bar bushing with grease.

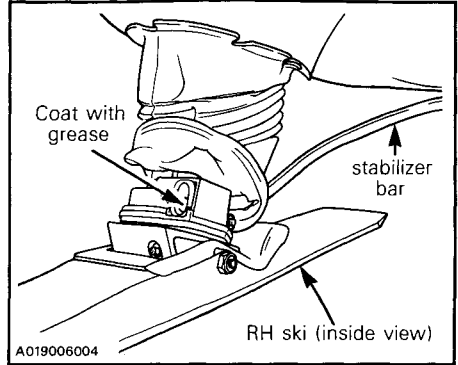

Drive Axle

Lubricate at grease fitting using low temperature grease.

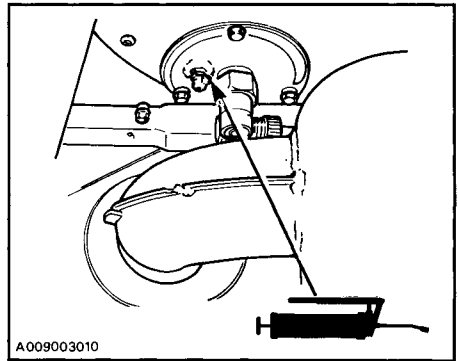

CAUTION: When lubricating the drive axle bearing, do not apply excessive grease as the seal will be pushed out of its housing. Check seal position with finger.

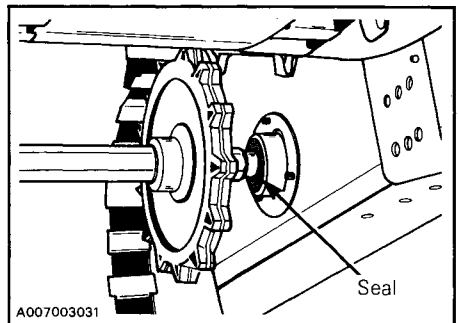

Slide Suspension

Lubricate the following parts at grease fittings until grease appears at joints. Use low temperature grease only.

Front upper cross shaft.

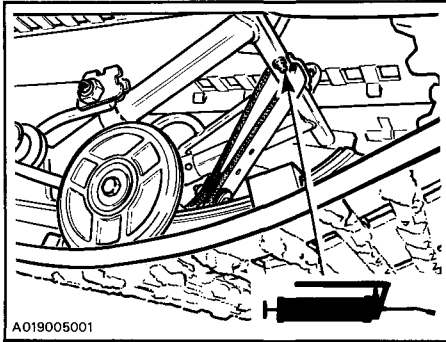

Front lower cross shaft.

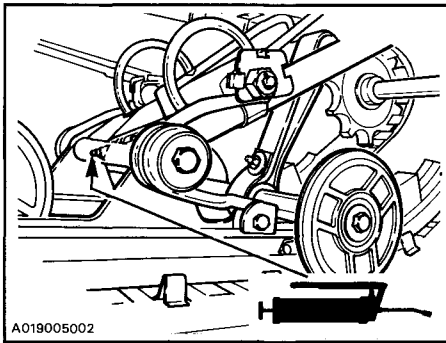

Rear cross shaft.

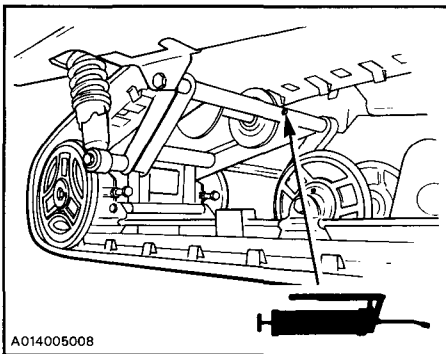

Chaincase Oil Level

Using the spark plug socket, remove the filler cap then using a rigid wire as a "dipstick" check oil level. The oil level on the "dipstick" should be 50-65 mm (2" to 2 1/2"). Refill as required using Bombardier chaincase oil (P/N 413 8019 00 - 200 ml).

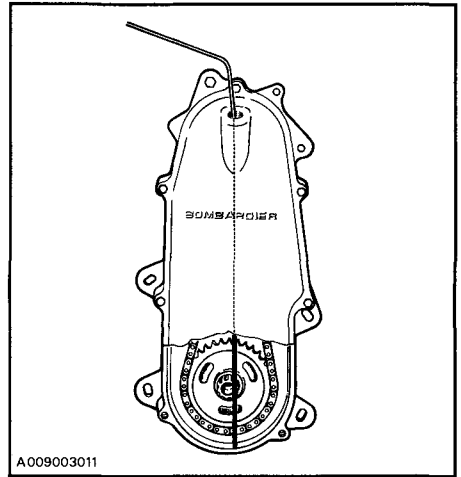

○ NOTE: The chaincase oil capacity is approximately 200 ml (7 oz).

Oil Injection System

Always maintain a sufficient amount of Bombardier Snowmobile Injection Oil in the injection oil tank.

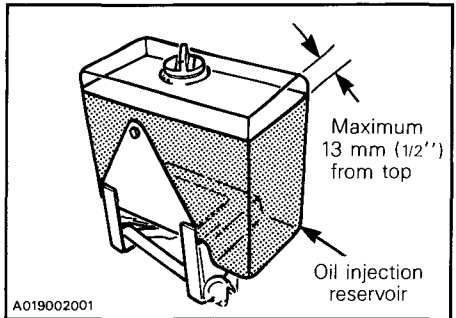

▼ CAUTION: Check level and refill every time you refuel. Do not overfill.

MAINTENANCE

The following Maintenance Chart indicates regular servicing schedules to be performed by the owner of the servicing dealer. If these services are performed as suggested, the snowmobile will provide many years of low-cost use.

WARNING: Only perform such procedures as detailed in this manual. It is recommended that dealer assistance be periodically obtained on other components/systems not covered in this manual. Unless otherwise specified, engine should be turned OFF for all lubrication and maintenance procedures.

MAINTENANCE CHART	Weekly or every 240 km (150 mi)	Monthly or every 800 km (500 mi)	Once year or every 3200 km (2000 mi)	Refer to page
Drive belt condition				24
Brake condition				24
Brake adjustment				25
Spark plugs				25
Battery (Electric starting)				25
Suspension condition				26
Suspension stopper strap condition				26
Suspension adjustment		(as required)		26
Track condition				28
Track tension and alignment				28
Drive pulley				29
Steering mechanism				30
Steering adjustment				30
Muffler attachment				31
Engine head nuts				31
Engine mount nuts				31
Carburetor adjustment				32
Injection oil filter condition				32
Oil injection pump adjustment				32
Fan belt				33
Headlamp beam aiming				33
General inspection				34

 **NOTE:** The ten hour inspection is a very important part of proper service and maintenance.

Belt Guard Removal

◆ **WARNING:** Engine should be running only when belt guard is secured in place.

1. Tilt the hood.
2. Pull out both retaining pins.

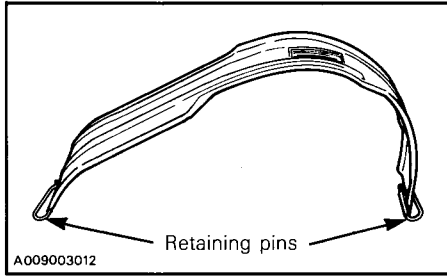

3. Lift and remove the belt guard assembly.

Drive Belt Removal and Installation

◆ **WARNING:** Never start or run engine without the drive belt installed. Running an unloaded engine is dangerous.

1. Remove the belt guard.
2. Unlock and raise driven pulley support.

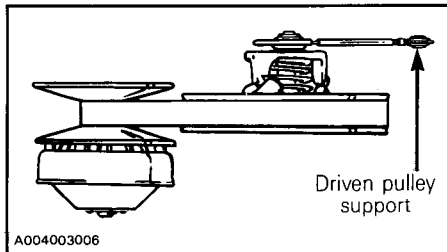

3. Open the driven pulley by twisting and pushing the sliding half. Hold in fully open position.

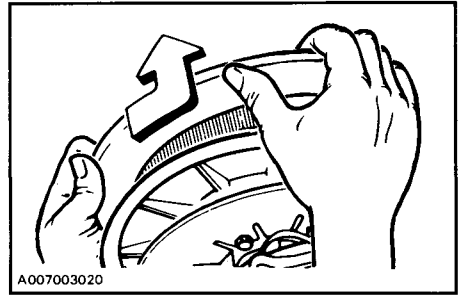

4. Slip slackened belt over the top edge of the sliding half.

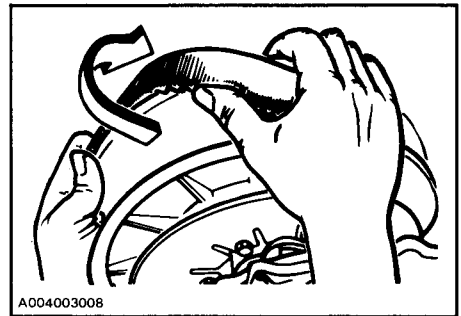

5. Slip the belt out from the drive pulley and remove completely from vehicle.

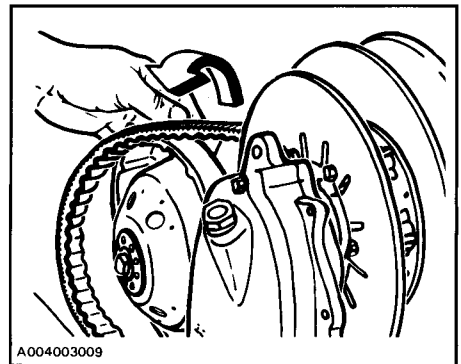

To install the drive belt, reverse the procedure, however pay attention to the following.

The maximum drive belt life span is obtained when the belt has the proper rotation direction. Install it so the printed information on the belt is in the way to be read when standing face to pulleys.

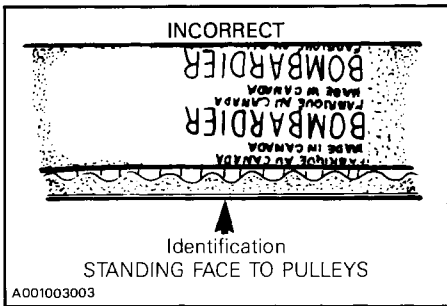
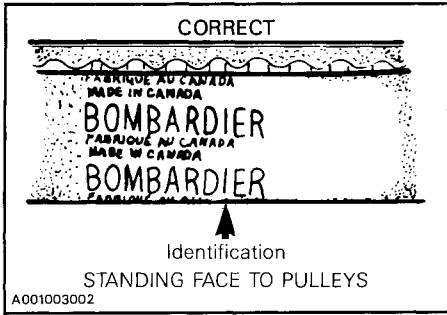

CAUTION: Do not force or use tools to pry the belt into place, as this could cut or break the cords in the belt.

Drive Belt Condition

Inspect belt for cracks, fraying or abnormal wear (uneven wear, wear on one side, missing cogs, cracked fabric). If abnormal wear is noted, probable cause could be pulley misalignment, excessive R.P.M. with frozen track, fast starts without warm-up period, burred sheave, oil on belt or distorted spare belt. Contact the dealer.

Check the drive belt width. If less than 32 mm (1 1/4 in), replace the drive belt.

New Drive Belt

When installing a new drive belt, break-in period of 25 km (15 miles) is strongly recommended.

NOTE: Always store a spare belt in a manner to allow its natural shape to be maintained.

Brake Condition

The brake mechanism on the snowmobile is an essential safety device. Keep this mechanism in proper working condition. Above all, do not operate the snowmobile without an effective brake system.

WARNING: Brake pads less than 3 mm (1/8") thick must be replaced. Replacement must be performed by an authorized dealer.

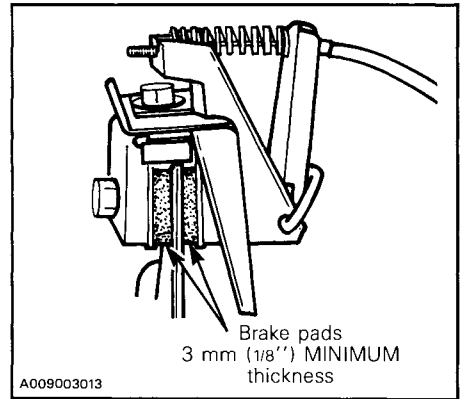

Brake Adjustment

The brake mechanism is a self-adjusting type. If a quicker brake response is desired, strongly pull the brake lever several times, this will actuate the self adjusting mechanism.

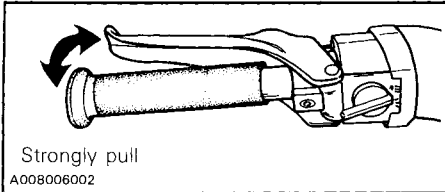

After the adjustment, brake should apply fully when lever is approximately 13 mm (1/2") from handlebar grip. If not, do not tamper with the brake, contact the dealer.

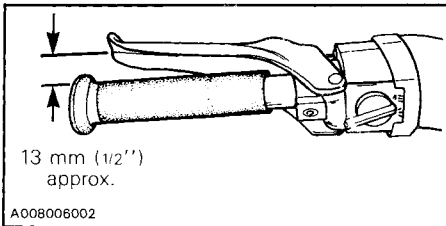

Spark Plugs

Disconnect the spark plug wires and remove the spark plugs.

Check the condition of the plugs.

- A brownish tip reflects ideal conditions. Carburetor adjustments, spark plug heat range, etc., are correct).
- A black insulator tip indicates fouling caused by: carburetor idle speed mixture and/or high speed mixture too rich, incorrect fuel mixture ratio, wrong type of spark plug (heat range), or excessive idling.
- A light grey insulator tip indicates a lean mixture caused by: carburetor high speed mixture adjusted too lean, wrong spark plug heat range, incorrect fuel mixture ratio, or a leaking seal or gasket.

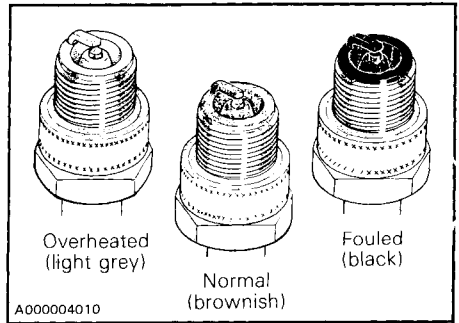

▼ **CAUTION:** If spark plug condition is not ideal, contact your authorized dealer.

Check spark plug gap using a wire feeler gauge.

Reinstall spark plugs and connect wires.

Battery

(Electric Starting)

Check electrolyte level weekly. Electrolyte level must be at upper level line on battery casing.

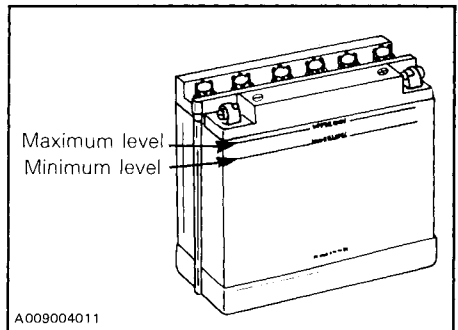

If necessary add distilled water. Battery connections must also be free of corrosion. If cleaning is necessary remove corrosion using a stiff brush then clean with a solution of baking soda and water. Rinse and dry well.

▼ **CAUTION:** Do not allow cleaning solution to enter battery. It will destroy the chemical properties of the electrolyte.

After reconnecting battery, coat battery terminals and connectors with petroleum jelly to prevent corrosion. Check that battery is well secured and that battery vent tube is not kinked or blocked.

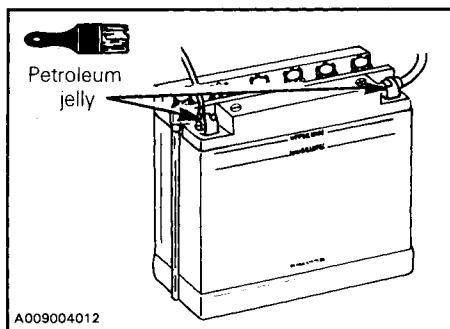

WARNING: Vent tube must be free and open. If not, it will restrict ventilation and create a gas accumulation that could result in an explosion. Avoid skin contact with electrolyte.

CAUTION: Prior to charging the battery, always remove it from the vehicle to prevent electrolyte spillage.

NOTE: Always keep battery fully charged. (To charge, refer to "Battery" in "Storage" section).

Suspension Condition

Visually inspect all suspension components including slider shoes, springs, wheels, etc.

NOTE: During normal driving, snow will act as a lubricant and coolant for the slider shoes. Extensive riding on ice or sanded snow, will create excessive heat build-up and cause premature slider shoe wear.

Stopper Strap Condition

Inspect strap for wear and cracks, bolt and nut for tightness. If loose inspect holes for deformation, replace as required. Torque nut to 10 N•m (89 lbf•in).

Suspension Adjustment

Front Suspension

The preload of front suspension shock absorber spring can be adjusted as follows:

POSITION	CONDITION
Lowest	Soft riding, smooth trail
Middle	Normal riding
Highest	Hard surface

Unhook ski leg boot spring and raise boot to gain access.

To adjust, use special key supplied in the tool box and turn spring collar accordingly.

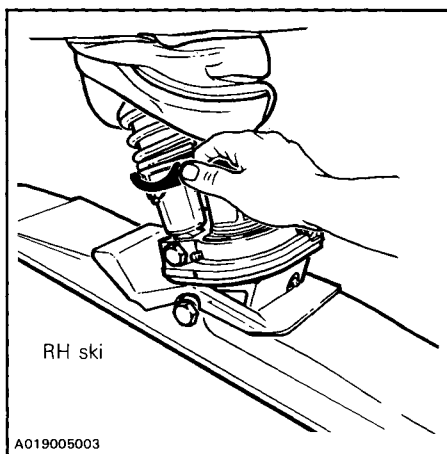
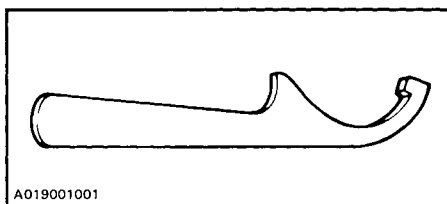

Reinstall boot and secure the spring.

Rear Suspension

ADJUSTER BLOCKS & SHOCK ABSORBER SPRINGS

The rear suspension is adjustable. The front adjuster blocks for surface condition, the rear shock absorber springs for driver's weight. Use special keys supplied in tool box.

ADJUSTER BLOCKS

Use this key to adjust

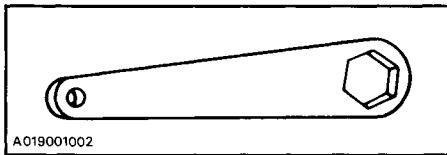

When the front adjuster blocks are at the lowest elevation more weight is distributed on the skis.

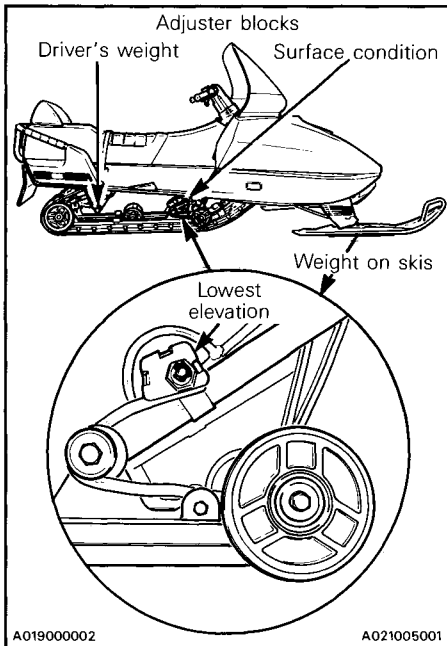

At the highest position the weight is transferred from the skis to the track.

NOTE: For deep snow condition or hill climbing, it is recommended to place the front adjuster blocks on the lowest position and set stopper strap to the shortest position.

CAUTION: Always turn the left side adjuster blocks in a clockwise direction, the right side blocks in a counter-clockwise direction. Left and right adjuster blocks of each adjustment must always be set at the same elevation.

SHOCK ABSORBER SPRINGS

Use this key to adjust.

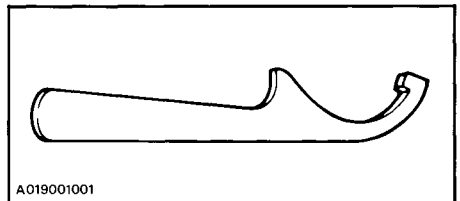

The preload of shock absorber springs can be adjusted as follow:

POSITION	DRIVER'S WEIGHT kg (lb)	
	FROM	UP TO
Lowest	—	68 (150)
Middle	68 (150)	82 (180)
Highest	82 (180)	—

To adjust, turn spring collar accordingly.

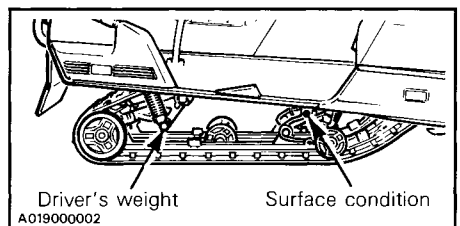

STOPPER STRAP

The function of the suspension stopper strap is to control the transfer of vehicle weight **during acceleration**. The longer the belt, the more the weight will be transferred to the track to provide a better traction. The shorter the belt, the lesser the weight transferred to the track, thus maintaining a more positive direction. Adjusting holes on the stopper strap allow to adjust it according to drivers' requirements, field and or snow conditions.

For normal use, insert bolt through strap holes as shown:

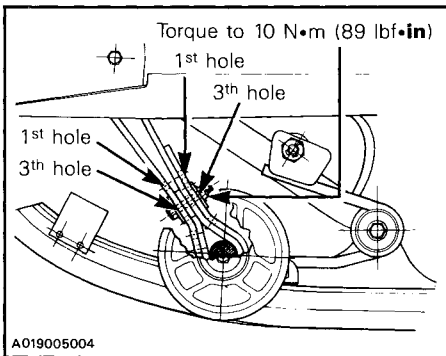

◆ **WARNING:** Always torque the nut to 10 N·m (89 lbf·in).

Track Condition

Lift the rear of the vehicle and support it off the ground. With the engine **OFF**, rotate the track by hand, and inspect condition. If worn or cut, or if track fibers are exposed, or if missing or defective inserts or guides are noted; contact the dealer.

◆ **WARNING:** Do not operate a snowmobile with a cut, torn or damaged track.

Track Tension and Alignment

Tension

Lift the rear of vehicle and support with a mechanical stand. Allow the slide to extend normally. The gap should be 13 mm (1/2'') between the slider shoe and the bottom inside of the track. If the track tension is too loose, the track will have a tendency to thump.

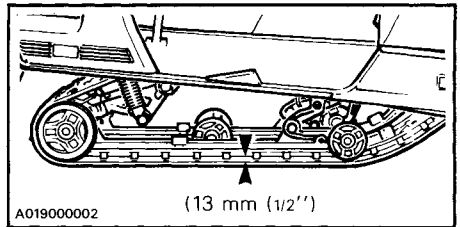

▼ **CAUTION:** Too much tension will result in power loss and excessive stresses on suspension components.

If necessary to adjust; loosen the rear idler wheel retaining screw and the adjuster bolt lock nut; then loosen or tighten the adjuster bolts located on the inner side of the rear idler wheels. If correct tension is unattainable, contact the dealer.

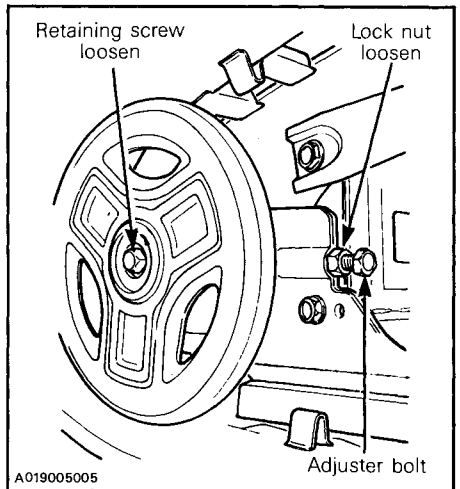

○ **NOTE:** Track tension and alignment are inter-related. Do not adjust one without the other.

Alignment

Start the engine and accelerate slightly so that track turns **slowly**. Check that the track is well centered; equal distance on both sides between edges of track guides and slider shoes.

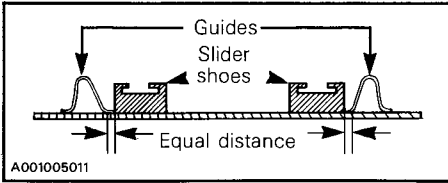

◆ **WARNING:** Before checking track alignment, ensure that the track is free of all particles which could be thrown out while track is rotating. Keep hands, tools, feet and clothing clear of track. Ensure no-one is standing in close proximity to the vehicle.

To correct, **stop the engine**, loosen the rear idler wheels retaining screws then loosen the lock nuts and tighten the adjuster bolt on side where the slider shoe is the farthest to the track insert guides.

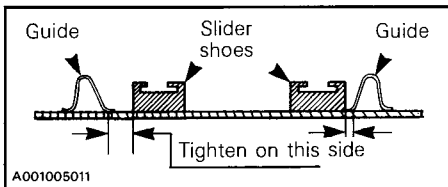

Tighten lock nuts and the idler wheel retaining screws.

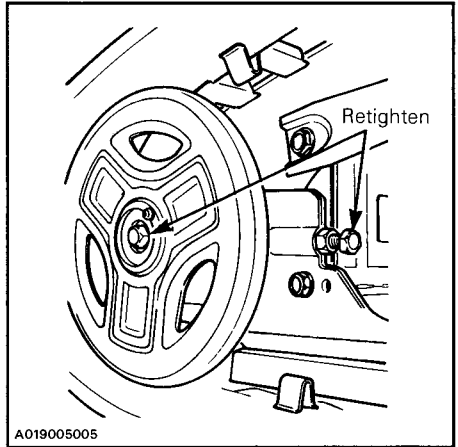

Restart engine, rotate track **slowly** and recheck alignment.

Drive Pulley

These vehicles are equipped with the latest in snowmobile transmission system. The TRA drive pulley (Total Range Adjustable). This pulley includes three (3) calibration screws that provide the opportunity to perform minor adjustments to the clutch in order to keep the engine at its peak power R.P.M., thereby maintaining optimal vehicle performance.

The clutch is factory adjusted position three (3) to provide the best performance under most riding conditions at sea level. However certain conditions, such as deep snow, high altitude, pulling a load, etc. may allow the engine to run below its peak power R.P.M. at wide open throttle thus decreasing the vehicle performance. Should such conditions be encountered the calibration screws can then be reset to allow the engine to operate at its peak power R.P.M. (given in technical data as max. HP R.P.M.).

The adjustment may be set at any one of six (6) positions, numbered from 1 to 6. Note that for casting purposes numeral one (1) appears as a dot. Each of these positions provides an increase or a decrease, in numerical order, of the engine speed by approximately 200 R.P.M.

Example:

(vehicle at sea level during full acceleration in normal conditions).

ADJUSTMENT SCREW	ENGINE SPEED
Position no 2	6800 R.P.M.
Position no 3	7000 R.P.M. (standard position)
Position no 4	7200 R.P.M.

Positions two (2) and four (4) allow the engine to run below or above it's power peak. Reducing vehicle performance.

○ **NOTE:** One must bear in mind that the purpose of these calibration screws is to maintain the engine R.P.M. at it's peak power, a lower or upper speed will actually result in less vehicle performance.

The point of maximum power, in the 1987 Stratos/Escapade occurs at about 7000 R.P.M. while the maximum permissible engine speed (red line) is 7500 R.P.M.

Adjustment Procedure

To change the calibration screw position; back off its locking nut and change the position of the calibration screw head. The notch on the screw head must be aligned with the desired numeral position. See illustration.

▼ **CAUTION:** Back off the calibration screw locking nut only far enough to allow a change of position of the screw head. **Never** attempt to remove the locking nut or the calibration screw. Make sure the adjustment is set at the **same** position for all three (3) screws.

◆ **WARNING:** Always retorque locking nut to 10 N•m (89 lbf•in).

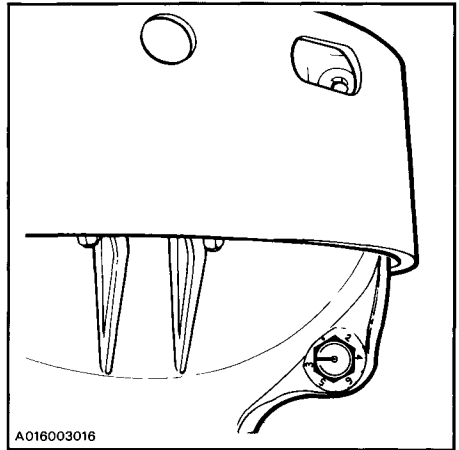

Steering Mechanism

Inspect the steering mechanism for tightness of components (steering arms, tie rods, ball joints, spring coupler bolts, etc.). If necessary, replace or retighten.

◆ **WARNING:** Check the condition of the skis and the ski runners. Replace if more than half worn.

Steering Adjustment

Skis should have a toe out of 3 mm (1/8"). To check, measure the distance between each ski at the front and rear of the ski. The front distance should be 3 mm (1/8") more than the rear when the handlebar is horizontal.

IMPORTANT: Close the front of the skis manually to eliminate all slack from the steering mechanism.

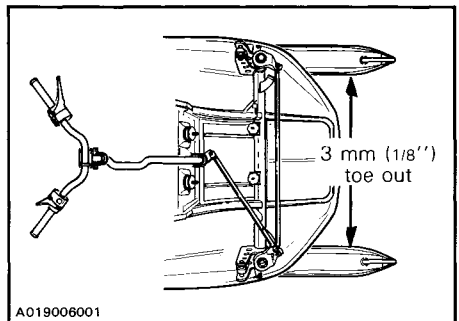

If adjustment is required:

Loosen the lock nuts of the longest tie rod. Turn the tie rod manually until the skis are properly aligned. Firmly retighten the lock nuts.

The handlebar should also be horizontal when the skis are pointed toward the front.

To adjust:

Loosen the lock nuts of the shortest tie rod. Turn the tie rod manually until the handlebar is horizontal. Retighten the lock nuts firmly.

WARNING: The ball joint socket must run parallel with the steering arm. The socket must be restrained when tightening the tie rod end lock nuts.

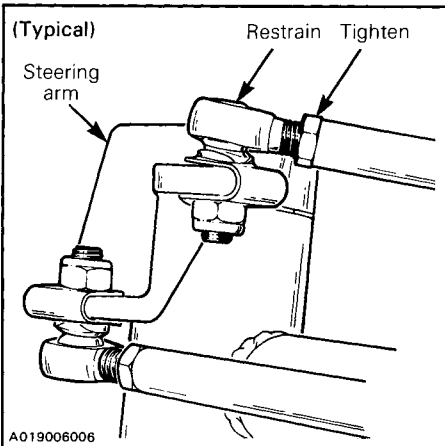
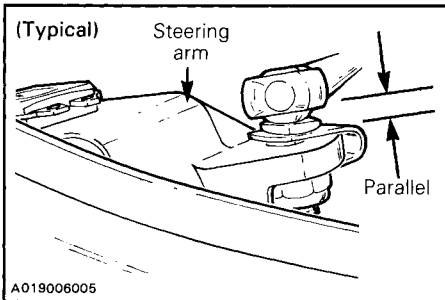

Muffler Attachment

The engine/exhaust system parts are vital toward efficient muffler function. Check all attachments. Replace the springs and/or tighten if necessary.

CAUTION: Do not operate vehicle with muffler disconnected otherwise serious engine damage will occur.

Engine Head Nuts

With the ENGINE COLD, check that the engine head nuts are tight and equally torqued to 21 N•m (15 lbf•ft).

Respect tightening sequence as follow:

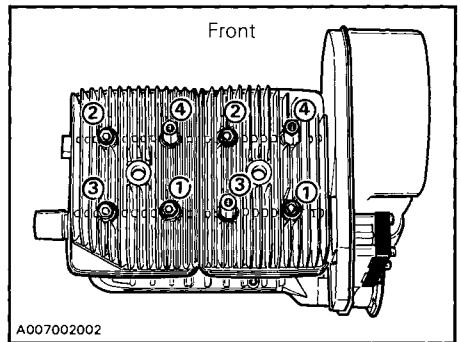

IMPORTANT: The engine head nut torque should be checked after the first 5 hours of operation.

Engine Mount Nuts

Check the engine mount nuts for tightness. Retighten if necessary.

Carburetor Adjustment

▼ **CAUTION:** Never operate your snowmobile with the air intake silencer disconnected. Serious engine damage will occur if this notice is disregarded.

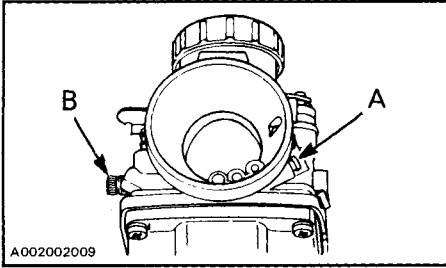

A) Air Screw Adjustment

Completely close the air screw (until a slight reseating resistance is felt) then back off screw: 1 1/4 turn.

B) Idle Speed Adjustment

Turn the idle speed screw clockwise until it contacts the throttle slide then continue turning two (2) additional turns. This will provide a preliminary idle speed setting. Start engine and allow it to warm then adjust idle speed to 1800-2000 R.P.M. by turning idle speed screw clockwise or counter-clockwise.

▼ **CAUTION:** Make sure both carburetors start to operate simultaneously.

▼ **CAUTION:** Do not attempt to set the idle speed by using the air screw. Severe engine damage can occur. If idle speed is unattainable contact the dealer.

Oil Injection System

Injection Oil Filter Condition

Inspect oil filter at least once a month. Insure that filter is not obstructed by foreign particles; if so, see the dealer.

▼ **CAUTION:** An obstructed injection oil filter will cause oil starvation resulting in serious engine damage.

○ **NOTE:** After a storage period, it is important that the dealer replace the injection oil filter and that the oil flow of the injection pump be checked.

Injection Pump Adjustment

Proper oil injection pump adjustment is very important. Any delay in the opening of the pump can result in serious engine damage.

▼ **CAUTION:** The carburetor must be adjusted before adjusting the oil injection pump. Make sure idle speed is 1800-2000 R.P.M.

To check adjustment: eliminate the throttle cable free-play by pressing the throttle lever until a light resistance is felt then hold in place. The aligning marks on the pump casting and lever must align perfectly. If not, contact the dealer.

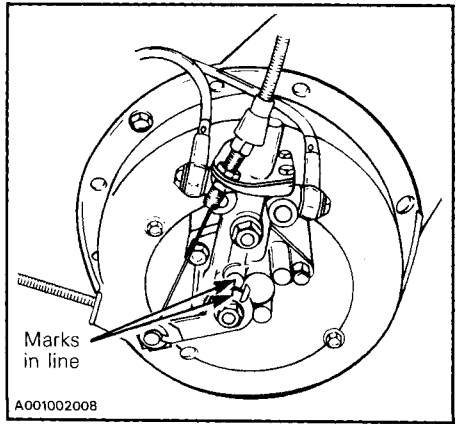

○ **NOTE:** Injection pump should be adjusted by the dealer.

Fan Belt

Inspect belt for cracks, uneven wear, etc. Check fan belt tension a 9-10 mm (3/8'') deflection should exist.

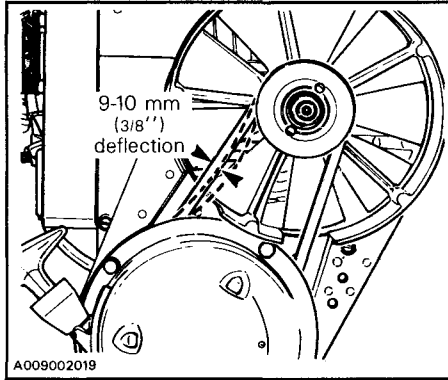

If belt seems damaged or if tension is incorrect, contact the dealer immediately.

WARNING: If fan protector is removed, always reinstall after servicing.

Headlamp Beam Aiming

The angle of the headlamp beam has been pre-adjusted prior to delivery. Should a re-adjustment is necessary, place the vehicle on a flat surface 7.6 m (25') from a wall or screen.

With the suspension correctly adjusted, the rider seated on the vehicle and the high beam ON check that the center of high intensity zone of high beam is 50 mm (2'') below horizontal line of headlamp height.

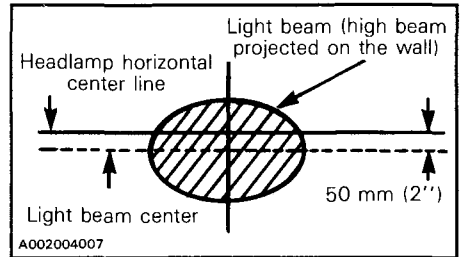
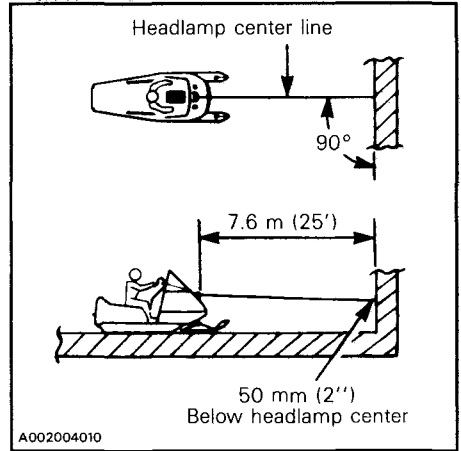

To adjust, remove the four caps, turn upper or lower adjusting screws to obtain desired beam position.

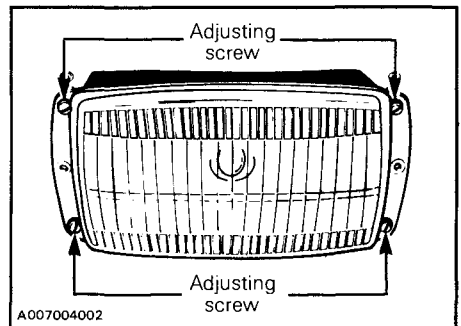

Bulb Replacement

If the headlamp bulb is burnt, tilt hood, unplug the connector from the headlamp. Remove the rubber boot and unfasten bulb retainer clips. Detach the bulb and replace.

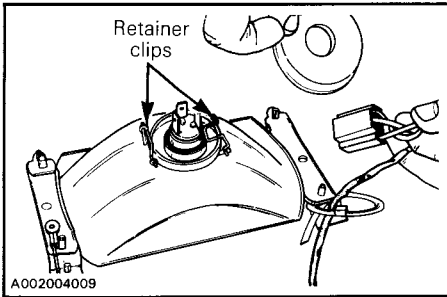

If taillight bulb is burnt, expose the bulb by removing the red plastic lens. To remove, unfasten the two (2) screws.

◆ **WARNING:** Always check light operation after bulb replacement.

General Inspection

Check the electrical wiring and components, retighten loose connections. Check for stripped wires or damaged insulation. Thoroughly inspect the vehicle and tighten loose bolts, nuts and linkage. Inspect skis and ski runners for wear.

STORAGE

It is during summer, or when a vehicle is not in use for any length of time that proper storage is a necessity. Storage of the snowmobile during long period of inactivity consists of checking and replacing missing, broken or worn parts, proper lubrication and treatment to insure that parts do not become rusted; cleaning items such as carburetor or oil mixtures, to prevent gum varnish formation within the carburetor; and in general, preparing the vehicle so that when the time comes to use the snowmobile again it will be in top condition.

◆ **WARNING:** Only perform such procedures as detailed in this manual. It is recommended that dealer assistance be periodically obtained on other components/systems not covered in this manual. Unless otherwise specified, engine should be turned OFF. For all lubrication and maintenance procedures.

Track

Inspect the track for wear, cuts, missing track guides and broken rods. Make any necessary replacement.

◆ **WARNING:** Do not operate a snowmobile with a cut, torn or damaged track.

Lift the rear of vehicle until track is clear of the ground then support with a brace or trestle. The snowmobile should be stored in such a way that the track does not stay in contact with the cement floor or bare ground.

○ **NOTE:** The track should be rotated periodically, (every 40 days). Do not release track tension.

▼ **CAUTION:** To prevent track damage, temperature in the storage area must not exceed 38°C (100°F).

Suspension

Remove any dirt or rust. Grease all components equipped with grease fittings. Wipe off surplus. Replace worn slider shoes.

Skis

Wash or brush all dirt or rust accumulation from the skis. Grease the ski legs at the grease fittings.

◆ **WARNING:** Check the condition of the skis, ski runners and springs. Replace if weak or worn more than half.

Controls

Lubricate the steering mechanism. Inspect all components for tightness, (spring coupler bolts, steering arm locking bolts, tie rods, ball joints, etc.) Tighten if necessary. Oil moving joints of the brake mechanism.

◆ **WARNING:** Do not lubricate the throttle and/or brake cables and housings. Avoid getting oil on the brake pads.

Coat all electrical connections and switches with a greaseless metal protector. If unavailable, use petroleum jelly.

Chaincase

Drain the chaincase and refill to proper level, using fresh chaincase oil (P/N 413 8019 00 - 200 ml). To drain, remove the chaincase cover.

Drive Pulley

Inspection and cleaning must be performed by the dealer at the end of each season.

Engine and Primer Lubrication

Engine internal parts must be lubricated to protect them from possible rust formation during the storage period.

To perform the storage procedures (engine and primer valve) proceed as follows:

1. Lift the rear of the vehicle and support it off the ground.

◆ **WARNING:** Ensure the track is free of all particles which could be thrown out while it is rotating. Keep hands, tools, feet and clothing clear of track. Ensure no-one is standing in close proximity to the vehicle.

2. Start the engine and allow it to run at idle speed until the engine reaches its operational temperature.
3. Stop the engine.
4. Disconnect the inlet primer hose from the primer valve.

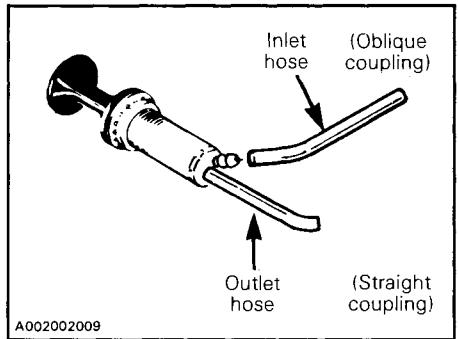

5. Plug inlet primer hose to prevent gasoline from draining.
6. Using an appropriate hose, connect one end of the hose to the inlet of the primer valve and place the other end in a Bombardier Snowmobile Injection Oil container.
7. Activate the primer in order to fill it with oil.
8. Restart engine and run at idle.

9. Using the primer valve, inject oil until the engine dies or until a sufficient quantity of oil has entered the engine (approximately 25 complete strokes of the primer).
10. The engine stopped, remove the spark plugs and pour approximately 85 ml (3 imp. oz.) of oil into the cylinders.
11. Crank the engine to allow the crankshaft to turn 2 or 3 revolutions.
12. Reinstall the spark plugs and the inlet primer hose.

Do not run engine during storage period.

Gas Tank and Carburetors

Remove the cap then using a syphon, remove the gasoline from tank.

WARNING: Gasoline is flammable and explosive under certain conditions. Always manipulate in a well ventilated area. Do not smoke or allow open flames or sparks in the vicinity.

Carburetors must be dried out completely to prevent gum formation during the storage period.

Once the fuel tank is emptied, remove the float chamber drain plug from carburetors. Drain carburetors.

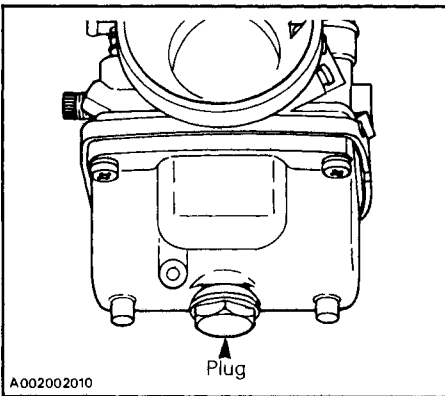

Reinstall plug.

Check all fuel lines, replace if necessary.

Battery

(Electric Starting)

1. Disconnect the battery cables and remove the battery retainer cover.

CAUTION: Be careful not to ground positive terminal with the chassis. Always disconnect black negative cable first.

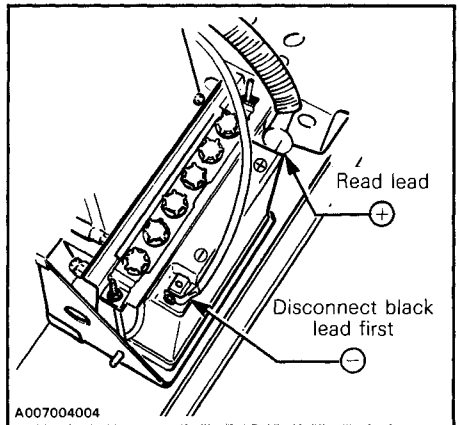

2. Remove the battery vent tube from the vent hole.
3. Lift out the battery.
4. Clean outside surface of battery with solution of baking soda and water. Remove all deposits from posts then rinse with clear tap water.

CAUTION: Do not allow cleaning solution to enter battery interior since it will destroy the electrolyte.

5. Check electrolyte level. Refill if necessary with distilled water. Fully charge battery at a maximum rate of 2.0 A.

CAUTION: Prior to charging the battery, always remove it from the vehicle to prevent electrolyte spillage.

◆ **WARNING:** Gases given off by a battery being charged are highly explosive. Always charge in a well ventilated area. Keep battery away from cigarettes or open flames. Avoid skin contact with electrolyte.

6. Coat electrical connections and switches with a greaseless metal protector, if unavailable, use petroleum jelly.
7. Store unit in a cool, dry place.

○ **NOTE:** To prevent battery from discharging, store it on a wooden shelf away from moisture. A stored battery must be recharged at least every 40 days.

Chassis

Clean the vehicle thoroughly, removing all dirt and grease accumulation.

▼ **CAUTION:** Plastic alloy components such as fuel tank, windshield, controls, etc., can be cleaned using mild detergents or isopropyl alcohol. Do not use strong soaps, degreasing solvents, abrasive cleaners, paint thinners, etc.

Inspect the hood and repair any damage. Clean the frame. For the unpainted aluminum portion use only "Aluminum cleaner" and follow instructions on the container.

Touch up all metal spots where paint has been scratched off. Spray all bare metal parts with metal protector. Wax the hood and the painted portion of the frame for better protection.

○ **NOTE:** Apply wax on glossy finish only. Protect the vehicle with a cover to prevent dust accumulation during storage.

▼ **CAUTION:** If for some reason the snowmobile has to be stored outside it is necessary to cover it with an opaque tarpaulin. This caution will prevent the sun rays and grime from affecting the plastic components and the vehicle finish.

General Inspection

Check the electrical wiring and components, retighten loose connections. Check for stripped wires or damaged insulation.

Thoroughly inspect the vehicle and tighten loose bolts, nuts and linkage.

○ **NOTE:** Leave the drive belt off the pulleys for the entire storage period.

Suspension Stopper Strap

Replace annually and/or as condition dictates. Torque nut to 10 N•m (89 lbf•in).

PRE-SEASON PREPARATION

To simplify the pre-season preparation we have drawn up a small chart. The chart indicates servicing points to be performed by you and your dealer. If these services are performed as suggested, your vehicle will give many hours of fun and low cost use.

IMPORTANT: Observe all Warnings and Cautions mentioned throughout this manual which are pertinent to the item being checked. When component conditions seem less than satisfactory, replace with genuine Bombardier parts or suitable equivalents.

PRE-SEASON PREPARATION CHART	TO BE PERFORMED BY DEALER	●
	TO BE PERFORMED BY OWNER	○
Reinstall battery (electric starting)		○
Change spark plugs*		○
Check chaincase oil level		○
Replace fuel filter (located inside fuel tank)		○
Check track tension and alignment		○
Lubricate suspension		○
Inspect drive belt and install		○
Check steering alignment and ski runner condition		○
Inspect condition of starting rope		○
Check tightness of all bolts, nuts and linkage		○
Refill gas tank		○
Check throttle cable for damage and free operation		●
Check electrical wiring (broken wire, damaged insulation)		○
Inspect seals for possible cuts or leaks		●
Replace injection oil filter		●
Refill injection oil tank		●
Inspect brake condition and operation		●
Set engine timing		●
Check pulleys, verify components and clean. Lubricate		●
Adjust carburetors		●
Adjust oil injection pump		●

○ ***NOTE:** Before installing new spark plugs, it is suggested to burn the excess storage oil by starting the engine, using the old spark plugs.

▼ **CAUTION:** Only perform this procedure in a well ventilated area.

TROUBLE SHOOTING

 **NOTE:** The possible causes have been listed in an order of frequency. Therefore items should be checked out in the same order as mentioned in the trouble shooting guide.

SYMPTOMS	POSSIBLE CAUSES	SOLUTIONS
Engine turns over but fails to start or starts with difficulty	1. No fuel to the engine	Check the tank level and fill it up with correct gas oil mixture. Check for possible clogging of fuel line, item 4.
	2. Flooded engine	Remove wet spark plugs, turn ignition to OFF and crank engine several times. Install clean dry spark plugs. Start engine following usual starting procedure. If engine continues to flood, see your dealer.
	3. Spark plug/faulty ignition	Check that emergency cut-out switch is at the upper position (ON) and the tether cut-out switch cap is snapped over the receptacle.
		Check for fouled or defective spark plug. Disconnect spark plug wire, unscrew plug and remove from cylinder head. Reconnect wire and ground exposed plug on engine cowl, being careful to hold away from spark plug hole . Follow engine starting procedure and check for spark. If no sparks appear, replace spark plug. If trouble persists, contact your dealer.
	4. Clogged fuel line (water or dirt)	Check condition and connections of fuel lines. Check the cleanliness of fuel tank.
	5. Incorrect carburetor adjustment	Contact your dealer.
	6. Too much oil in fuel	See the dealer for oil injection pump adjustment.
	7. Engine timing	Engine timing may be defective or out of adjustment. Contact your dealer.
8. Poor engine compression	Running with a lean fuel mixture may produce excessive engine wear resulting in poor engine compression. If this occurs, contact your dealer at once.	
Engine will not turn manually	1. Seized engine	In the case of a seized engine contact your dealer.

SYMPTOMS	POSSIBLE CAUSES	SOLUTIONS
Engine lacks acceleration or power	1. Fouled or defective spark plug	Check item 3 of "Engine turns over but fails to start or starts with difficulty"
	2. Clogged fuel line (water or dirt)	Check fuel line condition. (See item 4 of "Engine turns over but fails to start or starts with difficulty").
	3. Carburetor	Contact your dealer.
	4. Ignition	First check item 2 and 3 of "Engine turns over but fails to start or starts with difficulty". If the ignition system still seems faulty, contact your dealer.
	5. Engine	If unable to locate specific symptoms, contact your dealer.
Engine continually backfires	1. Spark plug	Check item 3 of "Engine turns over but fails to start or starts with difficulty".
	2. Overheated	Carburetor too lean, see your dealer.
	3. Engine timing incorrectly set	Contact your dealer.
Snowmobile cannot reach full speed	1. Drive Belt	Check for damaged or worn drive belt. Replace if necessary.
	2. Incorrect track adjustment	Check track tension and alignment. Readjust to specifications. (See Maintenance Section).
	3. Engine	Check item 1 to 5 of "Engine lacks acceleration or power".
	4. Pulley misaligned	Contact your dealer.

TOOLS

As standard equipment each new snowmobile is supplied with basic tools such as screwdriver, wrenches, emergency starter rope, etc.

Standard Tools

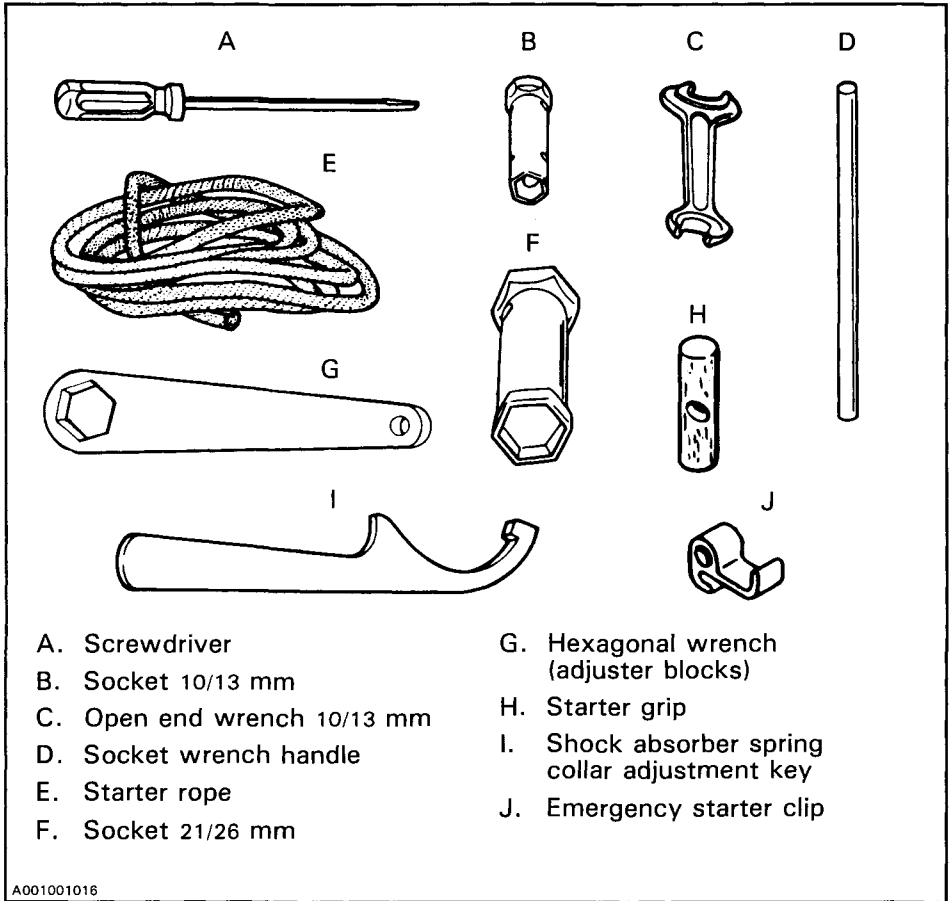

A001001016

SPECIFICATIONS

	Stratos	Escapade
ENGINE		
Type	503	
No of cylinders	2	
Bore	72 mm (2.835")	
Stroke	61 mm (2.402")	
Displacement	496.7 cm ³ (30.27 in ³)	
Compression ratio (corrected)	6.2:1	
Maximum horsepower R.P.M.*	7000	
Carburetor type	PTO: VM 34-364 MAG: VM 34-365	
Carburetor adjustment:		
— air screw	1 1/4 turn	
— idle speed	1800-2000 R.P.M.	
Fan belt deflection	9-10 mm (3/8")	
Torque:		
— engine head nuts	21 N•m (15 lbf•ft)	
— crankcase nuts	M6: 9 N•m (80 lbf•in) M8: 21 N•m (15 lbf•ft)	
— magneto ring nut	M22: 85 N•m (63 lbf•ft)	
— fan nut	M16: 65 N•m (48 lbf•ft)	
— crankcase engine support nuts	M10: 38 N•m (28 lbf•ft)	
— exhaust manifold bolts	M8: 21 N•m (15 lbf•ft)	
— electrical starter bolts	M8: 21 N•m (15 lbf•ft)	N.A.
CHASSIS		
Overall length	276.9 cm (109")	280.9 cm (111")
Overall width	105.9 cm (41.7")	
Overall height	124.9 cm (49.2")	
Ski stance (center to center)	81.9 cm (32.25")	
Ski alignment (toe out)	3 mm (1/8")	
Torque:		
— steering column/handlebar	26 N•m (19 lbf•ft)	
Weight	190.5 kg (420 lb)	215.5 kg (475 lb)
Bearing area	7064 cm ² (1095 in ²)	7594 cm ² (1177 in ²)
Ground pressure	2.7 kPa (.383 lb/in ²)	2.8 kPa (.404 lb/in ²)

*The maximum horse power RPM is applicable with engine on the vehicle. It may be different under certain circumstances and Bombardier Inc. reserves the right to modify it without any obligation.

	Stratos	Escapade
POWER TRAIN		
Track:		
– width		41.9 cm (16 1/2'')
– length	290 cm (114'')	315 cm (124'')
– tension	13 mm (1/2'') gap between slider shoe and bottom inside of track.	
– alignment	Equal distance between edges of track guides and slider shoes.	
Standard gear ratio	19/39	
Drive belt:		
– number	414 6175 00	
– Max. width	34.9 mm (1 3/8'')	
– Min. width	31.7 mm (1 1/4'')	
Chaincase oil	200 ml (7 oz)	
ELECTRICAL		
Lighting system (output)	12 V 160 W	
Bulb:		
– headlamp	60/55 W HAL.	
– tail/stop	5/21 W	
– speedometer	5 W	
– tachometer	5 W	
– electric fuel level gauge	2 W	
Fuse:		
– starter solenoid	30 A	
– tachometer	.1 A	
Spark plug:		
– type	BR9ES	
– gap	0.4 mm (0.016'')	
Ignition timing:		
– timing mark (B.T.D.C)	2.29 mm (.090'') (20°)	
– stroboscopic timing	6000 R.P.M.	
FUEL		
Gas type	Regular leaded or unleaded	
Fuel tank capacity		
– SI	28.6 liters	
– Imp.	6.3 gals	
– U.S.	7.6 gals	
Injection oil		
Type	Bombardier snowmobile injection oil	
Tank capacity		
– SI	2.6 liters	
– Imp.	92 oz	
– U.S.	88 oz	
BRAKE		
Type	Disc, self-adjusting	
Lining minimum thickness	3 mm (1/8'')	
Control lever adjustment	13 mm (1/2'') minimum distance from handlebar grip when fully applied.	

N.A.: Not applicable

HAL.: Halogen

Bombardier Inc. reserves the right to make changes in design and specifications and/or to make additions to, or improvements in its product without imposing any obligation upon itself to install them on its products previously manufactured.

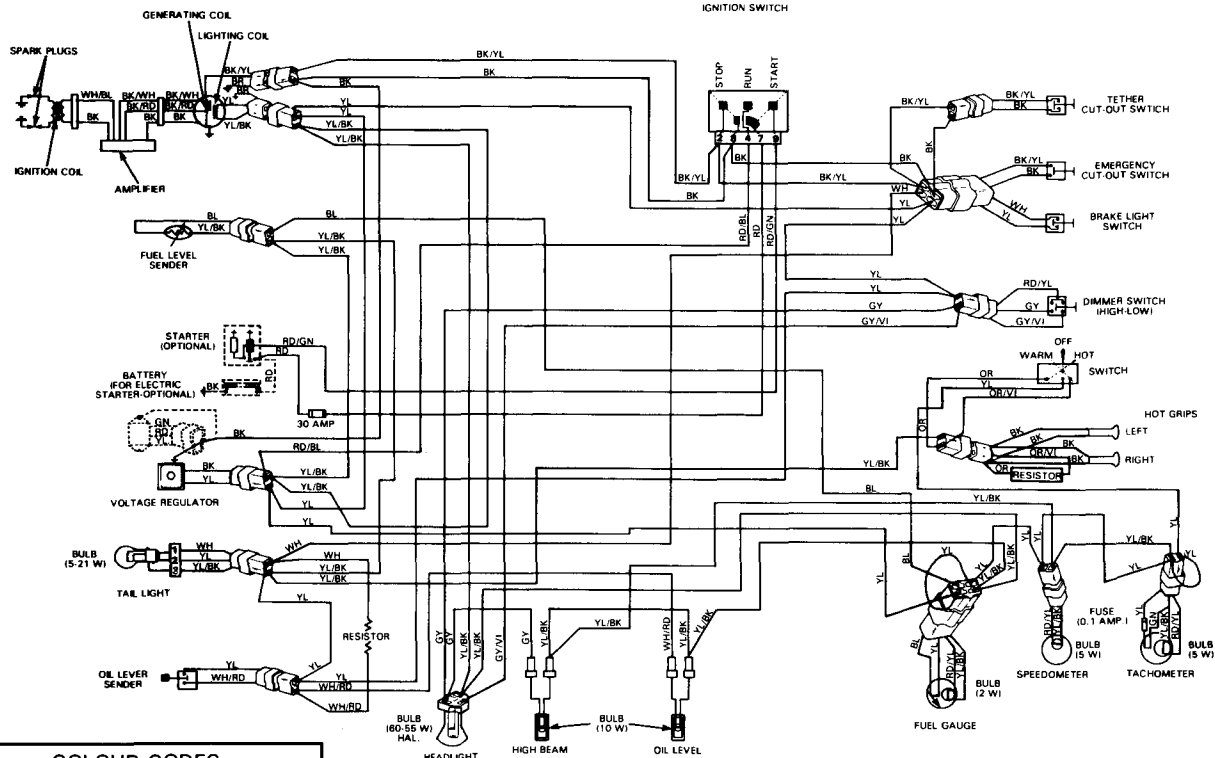

COLOUR CODES

BK — BLACK	GN — GREEN
WH — WHITE	GY — GREY
RD — RED	VI — VIOLET
BL — BLUE	OR — ORANGE
YL — YELLOW	BR — BROWN

INDICATOR LIGHTS

WARNING: Ensure all terminals are properly crimped on the wires and all connector housings are properly fastened.

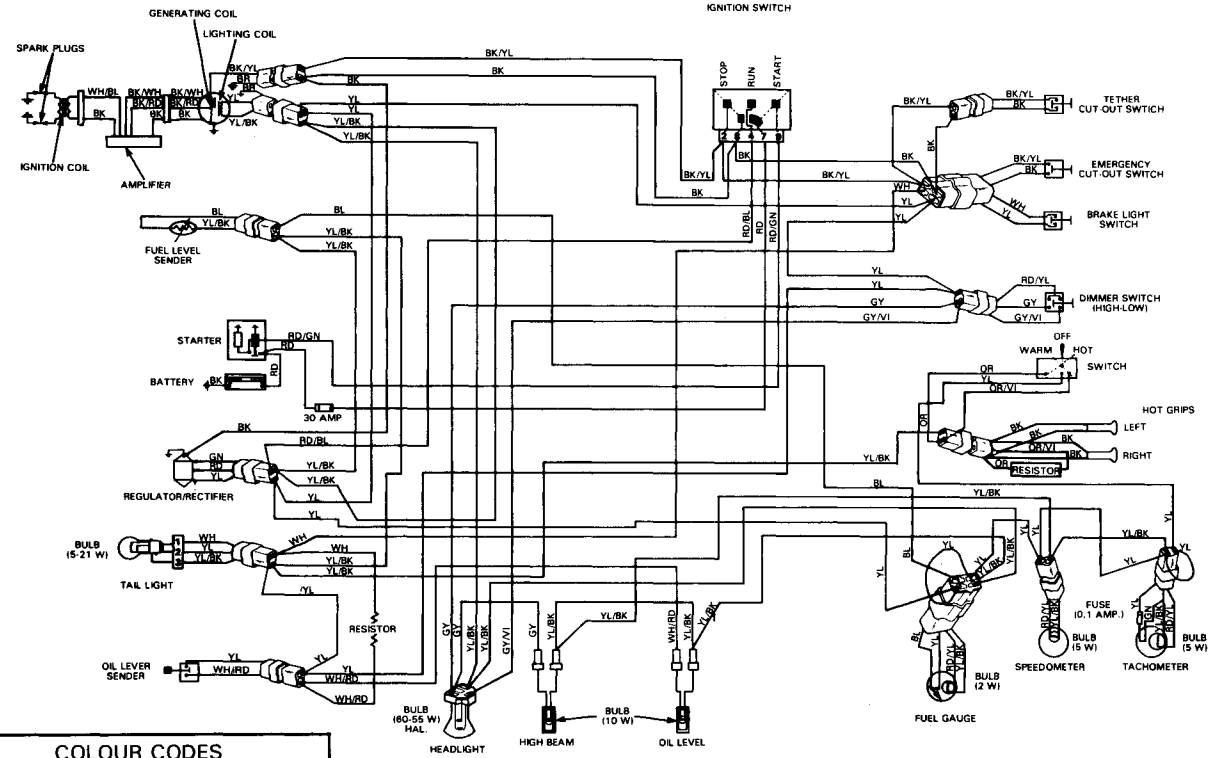

COLOUR CODES	
BK - BLACK	GN - GREEN
WH - WHITE	GY - GREY
RD - RED	VI - VIOLET
BL - BLUE	OR - ORANGE
YL - YELLOW	BR - BROWN

WARNING: Ensure all terminals are properly crimped on the wires and all connector housings are properly fastened.

SI* METRIC INFORMATION GUIDE

BASE UNITS			
DESCRIPTION	UNIT	SYMBOL	
length	meter	m	
mass	kilogram	kg	
force	Newton	N	
liquid	liter	l	
temperature	Celsius	°C	
pressure	kilopascal	kPa	
torque	Newton meter	N•m	
speed	kilometer per hour	km/h	

PREFIXES			
PREFIX	SYMBOL	MEANING	VALUE
kilo	k	one thousand	1000
centi	c	one hundredth of	0.01
milli	m	one thousandth of	0.001

CONVERSION FACTORS			
TO CONVERT	TO †	MULTIPLY BY	
lbf•ft	lbf•in	12	
imp. oz	U.S. oz	0.96	
imp. gal.	U.S. gal.	1.2	
in	mm	25.4	
in	cm	2.54	
ft	m	0.3	
MPH	km/h	1.61	
in ²	cm ²	6.45	
in ³	cm ³	16.39	
imp. oz	ml	28.41	
U.S. oz	ml	29.57	
imp. gal.	l	4.55	
U.S. gal.	l	3.79	
oz	g	28.35	
lb	kg	0.45	
lbf	N	4.4	
lbf•in	N•m	0.11	
lbf•ft	N•m	1.36	
PSI	kPa	6.89	
Fahrenheit	Celsius	(°F - 32) x 5/9	
Celsius	Fahrenheit	(°C x 1.8) + 32	

*The international system of units abbreviates "SI" in all languages.

† To obtain the inverse sequence, divide by the given factor. To convert "mm" to "in", divide by 25.4.

NOTES

NOTES

CHANGE OF ADDRESS OR OWNERSHIP

Any change in address or ownership should be brought to the attention of the manufacturer by completing and sending out the card supplied below.

NOTICE TO ALL NEW OWNERS: Make sure to receive the warranty registration card from the previous owner, at the time the ownership is transferred. Also enclose a photocopy of this registration card when informing of a change of ownership.



CHANGE OF ADDRESS

VEHICLE IDENTIFICATION NUMBER

--	--	--	--	--	--	--	--	--	--	--	--	--	--	--	--	--	--	--	--

OLD ADDRESS:

NAME

NO STREET APT.

CITY STATE/PROVINCE ZIP/POSTAL CODE

NEW ADDRESS:

NAME

NO STREET APT.

CITY STATE/PROVINCE ZIP/POSTAL CODE



CHANGE OF OWNERSHIP

VEHICLE IDENTIFICATION NUMBER

--	--	--	--	--	--	--	--	--	--	--	--	--	--	--	--	--	--	--	--

The ownership of this vehicle is transferred

FROM:

NAME

NO STREET APT.

CITY STATE/PROVINCE ZIP/POSTAL CODE

TO:

NAME

NO STREET APT.

CITY STATE/PROVINCE ZIP/POSTAL CODE



STAMP

BOMBARDIER INC.
ATT.: WARRANTY DEPARTMENT
VALCOURT, QUEBEC
CANADA, JOE 2LO

STAMP

BOMBARDIER INC.
ATT.: WARRANTY DEPARTMENT
VALCOURT, QUÉBEC
CANADA, JOE 2LO