

Elan

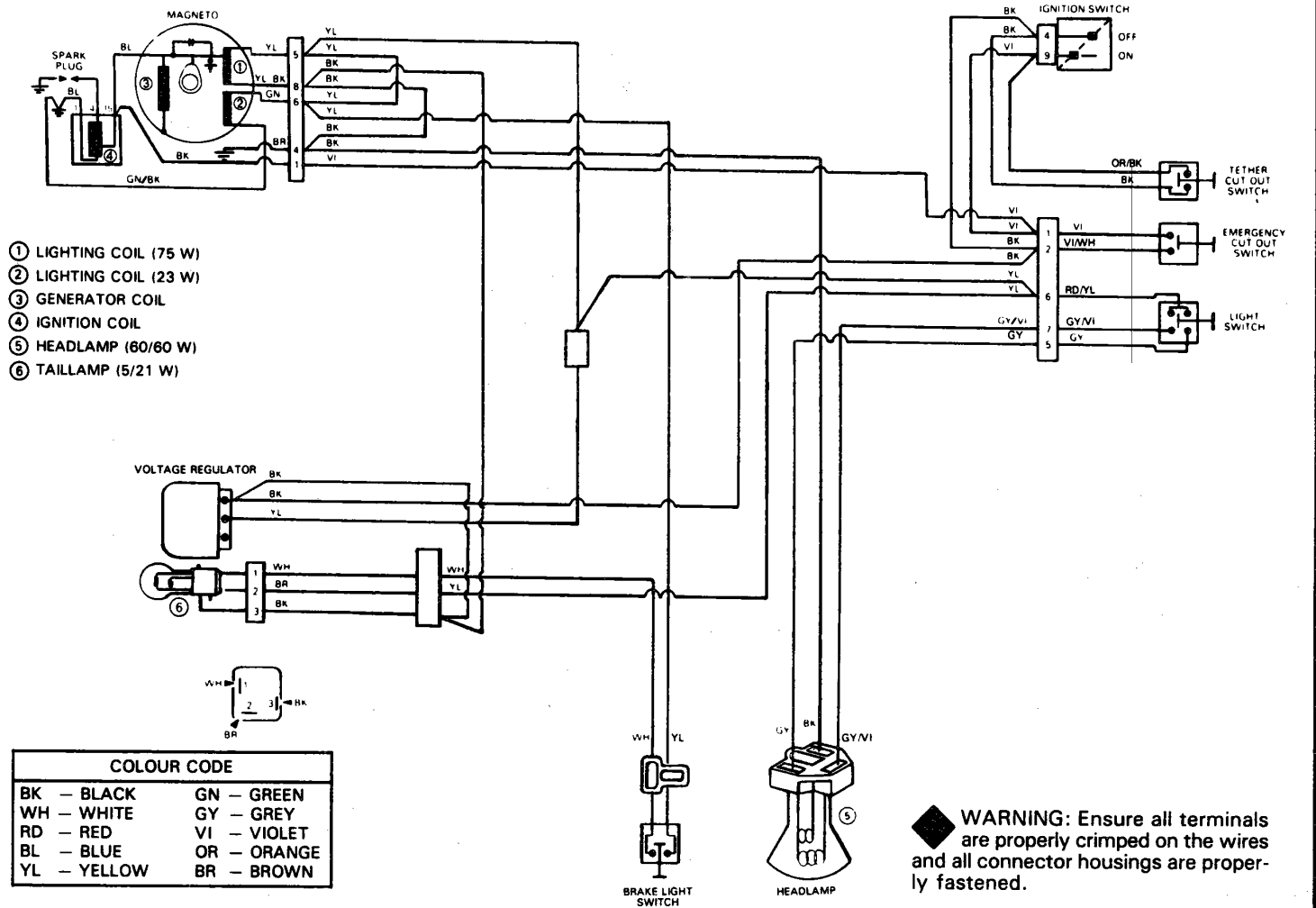

# Citation LS, Tundra & Tundra LT

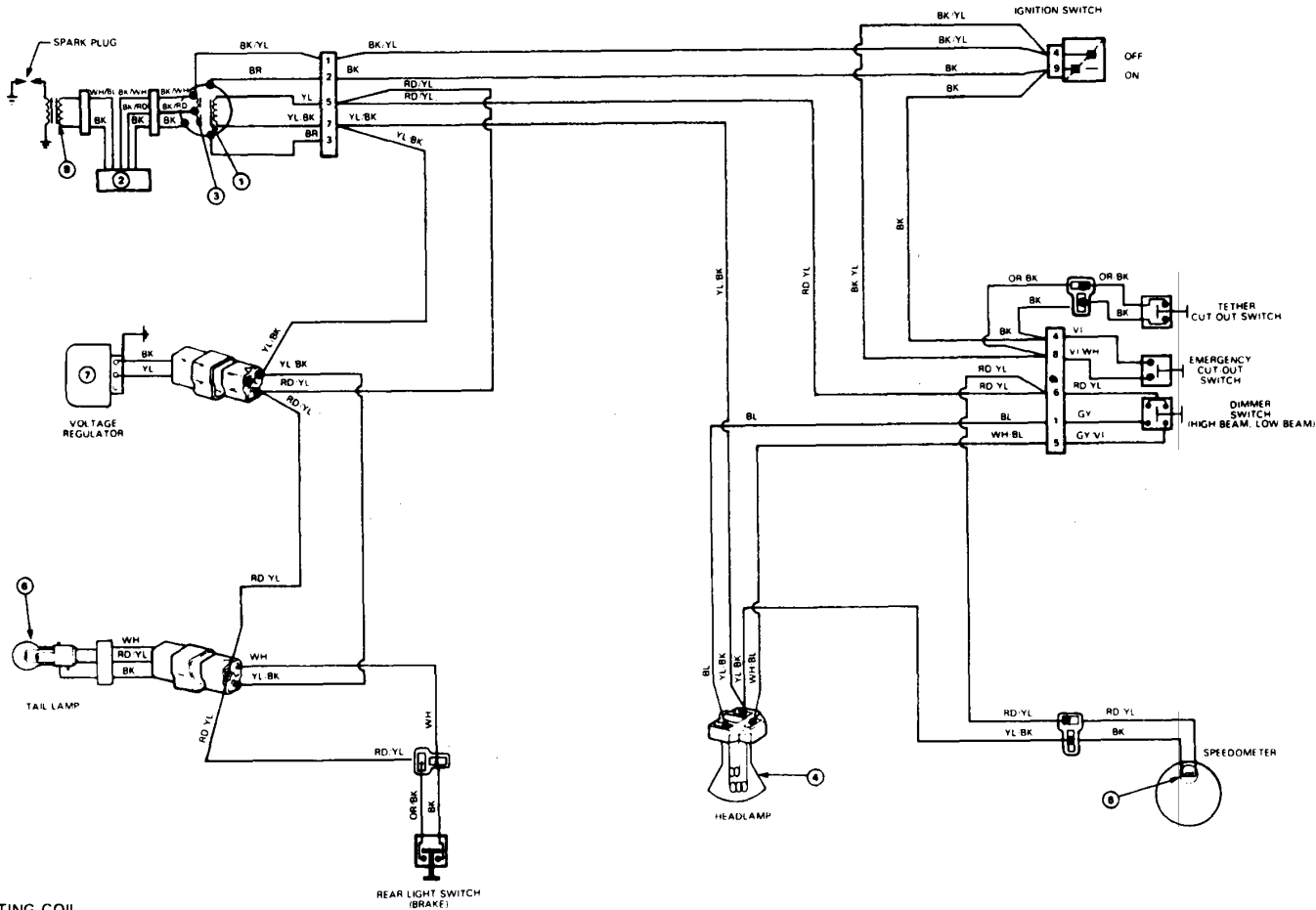

- ① LIGHTING COIL
- ② AMPLIFIER
- ③ GENERATOR COIL
- ④ HEADLAMP (60/60 W)
- ⑤ LIGHT (5 W)
- ⑥ REAR LAMP (5-21 W)
- ⑦ VOLTAGE REGULATOR
- ⑧ IGNITION COIL

**WARNING:** Ensure all terminals are properly crimped on the wires and all connector housings are properly fastened.

COLOUR CODE	
BK - BLACK	GN - GREEN
WH - WHITE	GY - GREY
RD - RED	VI - VIOLET
BL - BLUE	OR - ORANGE
YL - YELLOW	BR - BROWN

Citation LSE

Section 04 ELECTRICAL  
Sub-section 01 (ELECTRIC CHARTS)

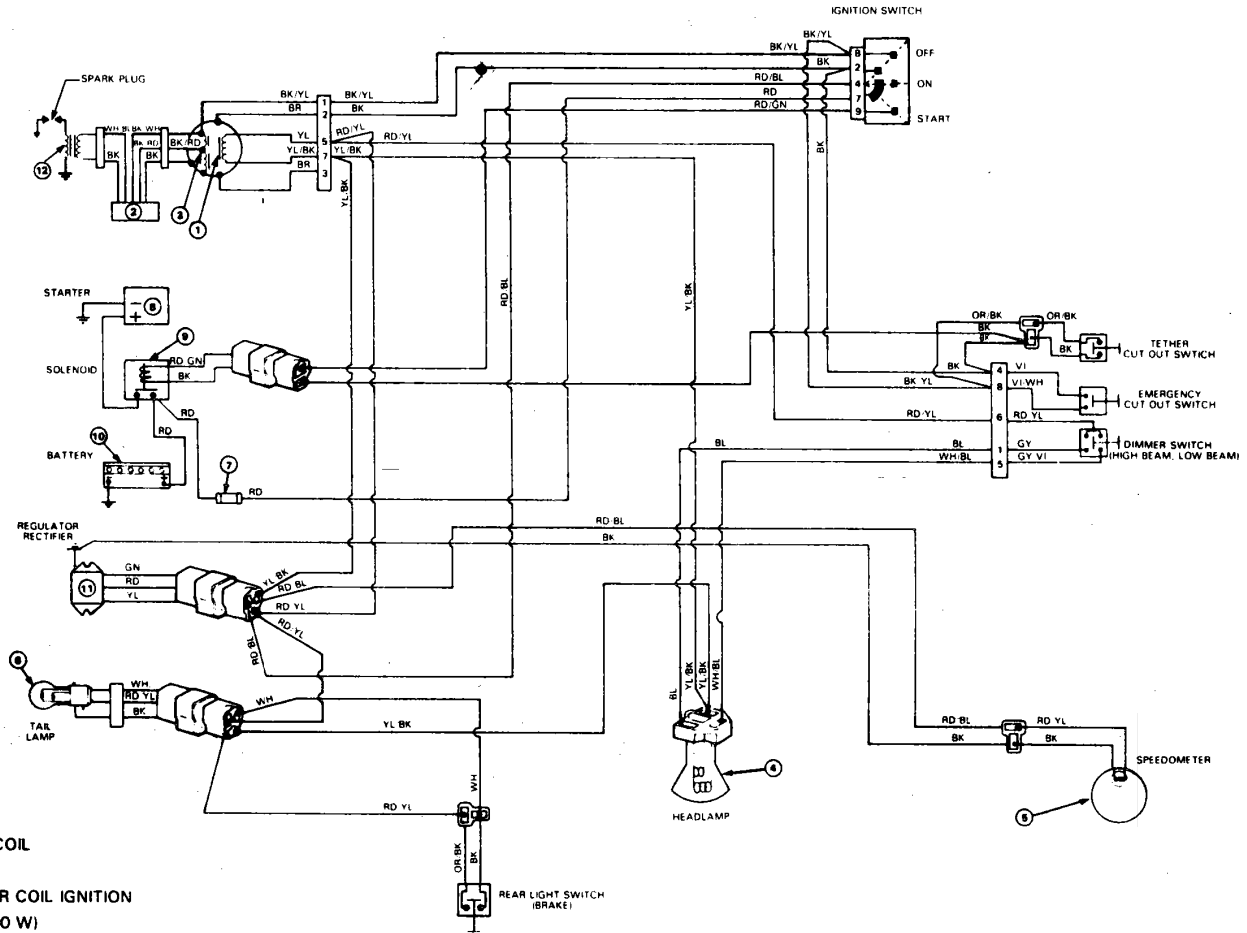

- ① LIGHTING COIL
- ② AMPLIFIER
- ③ GENERATOR COIL IGNITION
- ④ BULB (60/60 W)
- ⑤ BULB (5 W)
- ⑥ REAR BULB (5-21 W)
- ⑦ FUSE (30 A)
- ⑧ STARTER
- ⑨ SOLENOID
- ⑩ BATTERY (24 A)
- ⑪ REGULATOR RECTIFIER
- ⑫ IGNITION COIL

◆ **WARNING:** Ensure all terminals are properly crimped on the wires and all connector housings are properly fastened.

COLOUR CODE	
BK - BLACK	GN - GREEN
WH - WHITE	GY - GREY
RD - RED	VI - VIOLET
BL - BLUE	OR - ORANGE
YL - YELLOW	BR - BROWN

# Skandic 377/R

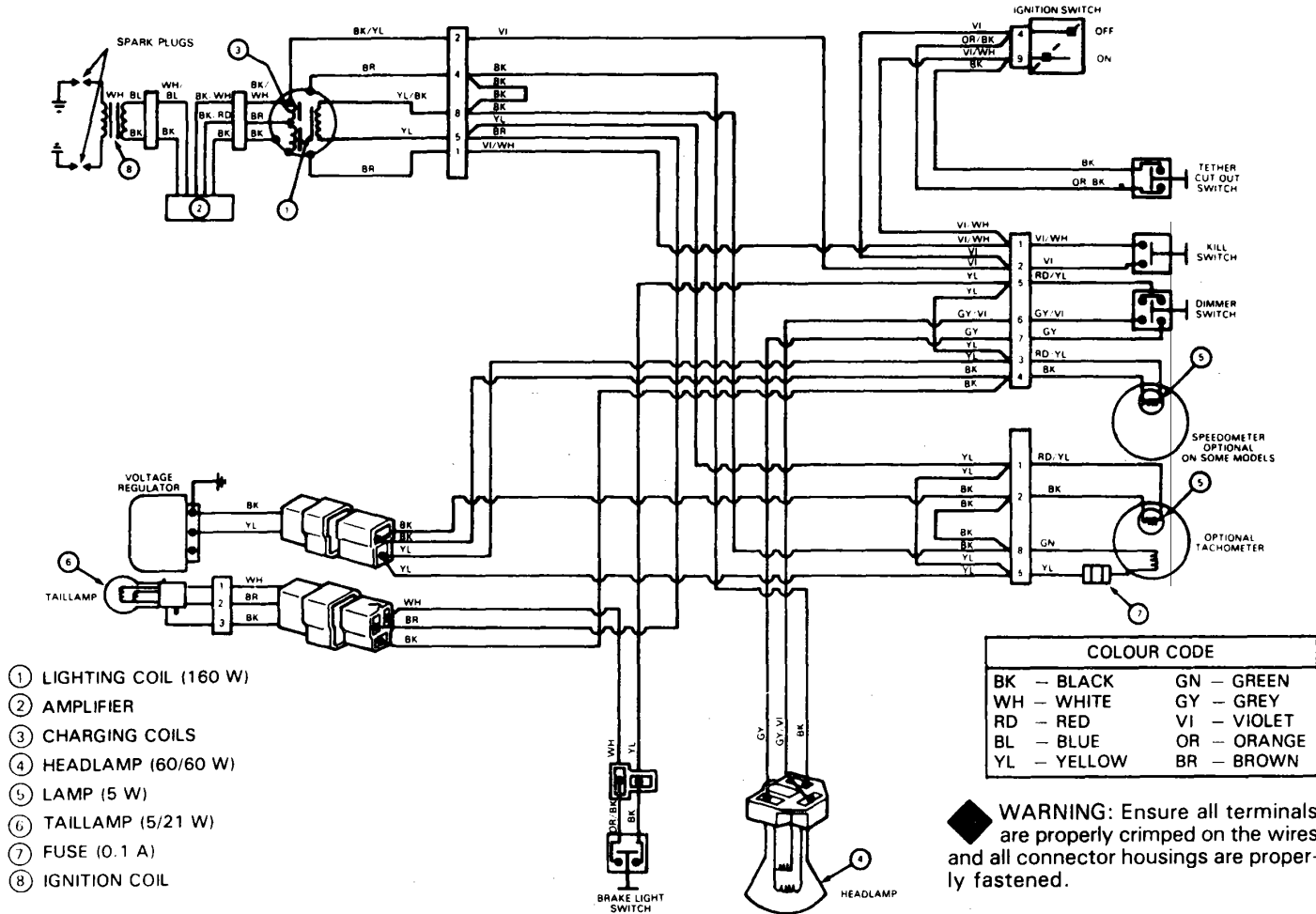

- ① LIGHTING COIL (160 W)
- ② AMPLIFIER
- ③ CHARGING COILS
- ④ HEADLAMP (60/60 W)
- ⑤ LAMP (5 W)
- ⑥ TAIL LAMP (5/21 W)
- ⑦ FUSE (0.1 A)
- ⑧ IGNITION COIL

04-01-5

Section 04 ELECTRICAL  
Sub-section 01 (ELECTRIC CHARTS)

Safari 377 & 447  
Mirage III

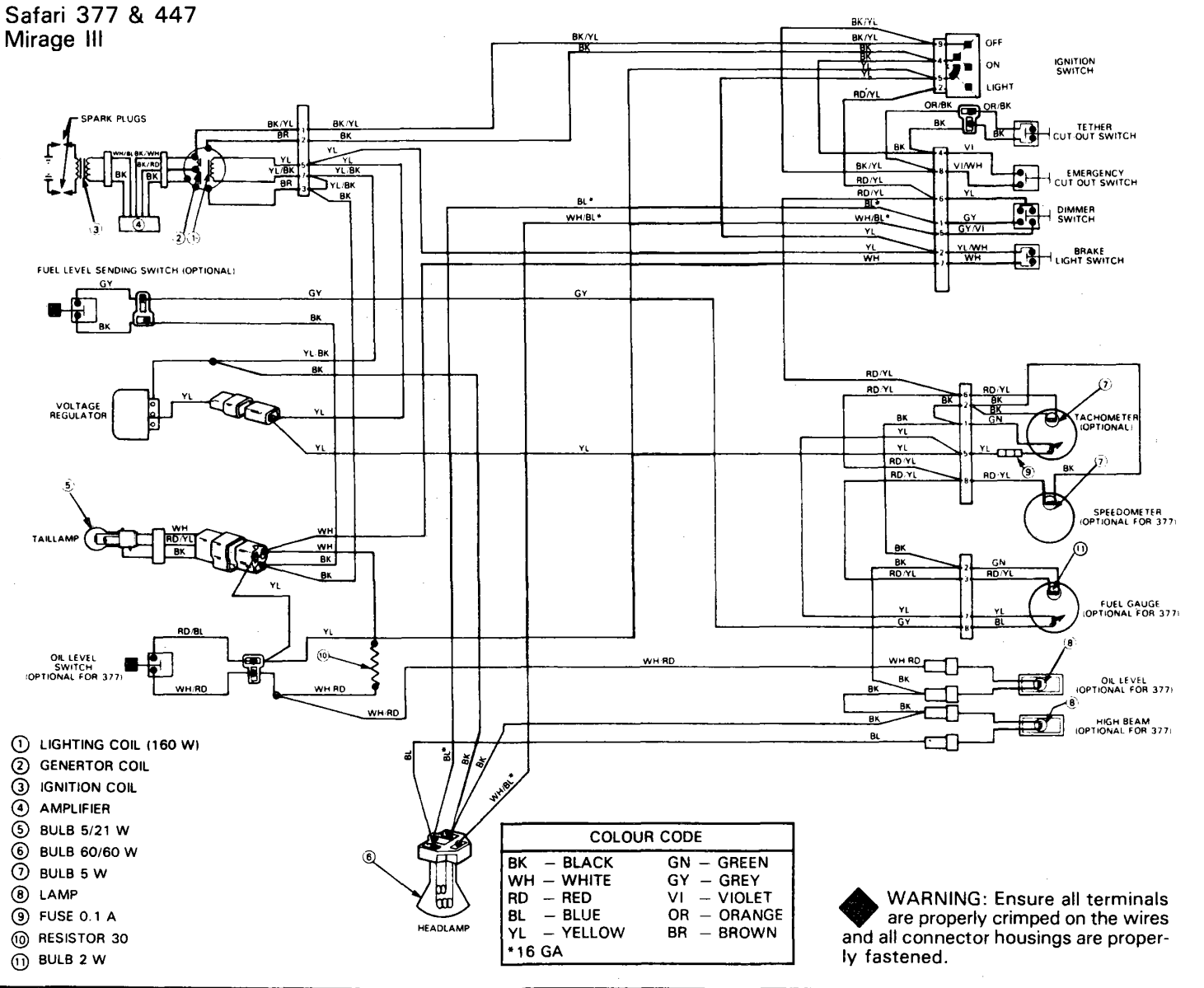

# Safari 377/E

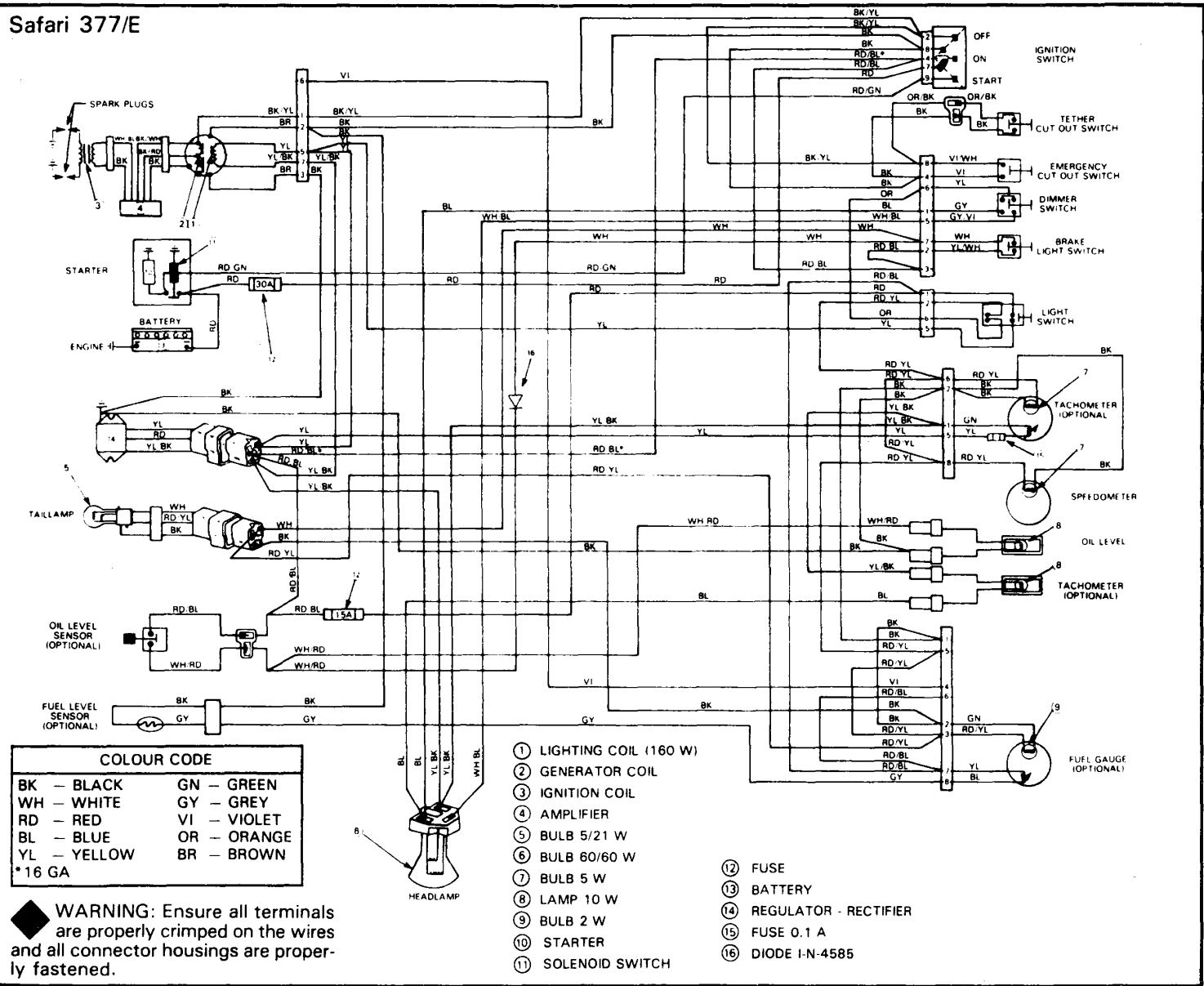

04-01-7

# Safari Grand Luxe LC

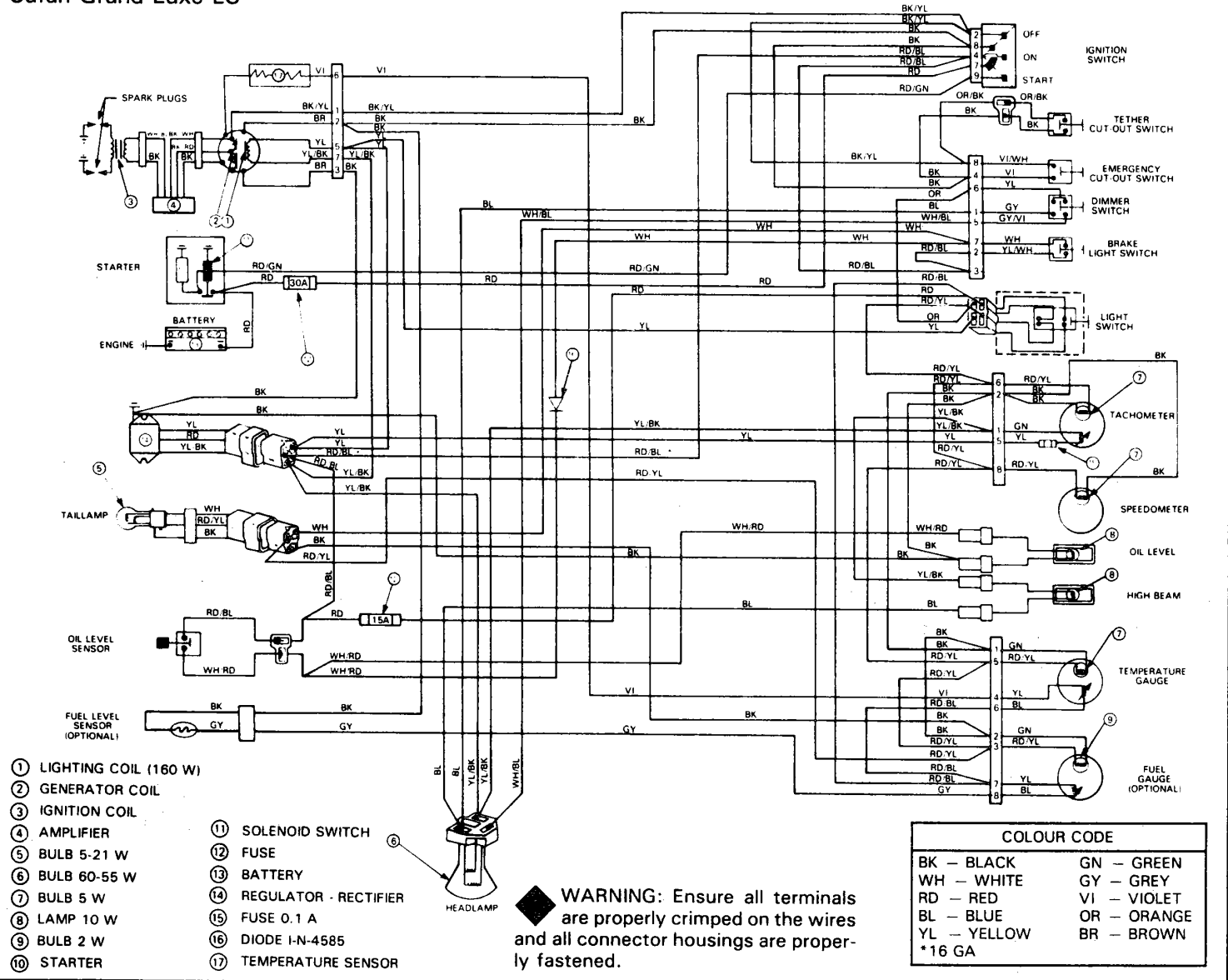

- ① LIGHTING COIL (160 W)
- ② GENERATOR COIL
- ③ IGNITION COIL
- ④ AMPLIFIER
- ⑤ BULB 5-21 W
- ⑥ BULB 60-55 W
- ⑦ BULB 5 W
- ⑧ LAMP 10 W
- ⑨ BULB 2 W
- ⑩ STARTER

- ⑪ SOLENOID SWITCH
- ⑫ FUSE
- ⑬ BATTERY
- ⑭ REGULATOR - RECTIFIER
- ⑮ FUSE 0.1 A
- ⑯ DIODE 1-N-4585
- ⑰ TEMPERATURE SENSOR

**WARNING:** Ensure all terminals are properly crimped on the wires and all connector housings are properly fastened.

COLOUR CODE	
BK - BLACK	GN - GREEN
WH - WHITE	GY - GREY
RD - RED	VI - VIOLET
BL - BLUE	OR - ORANGE
YL - YELLOW	BR - BROWN
*16 GA	

Formula SS, SP  
Formula MX-Plus

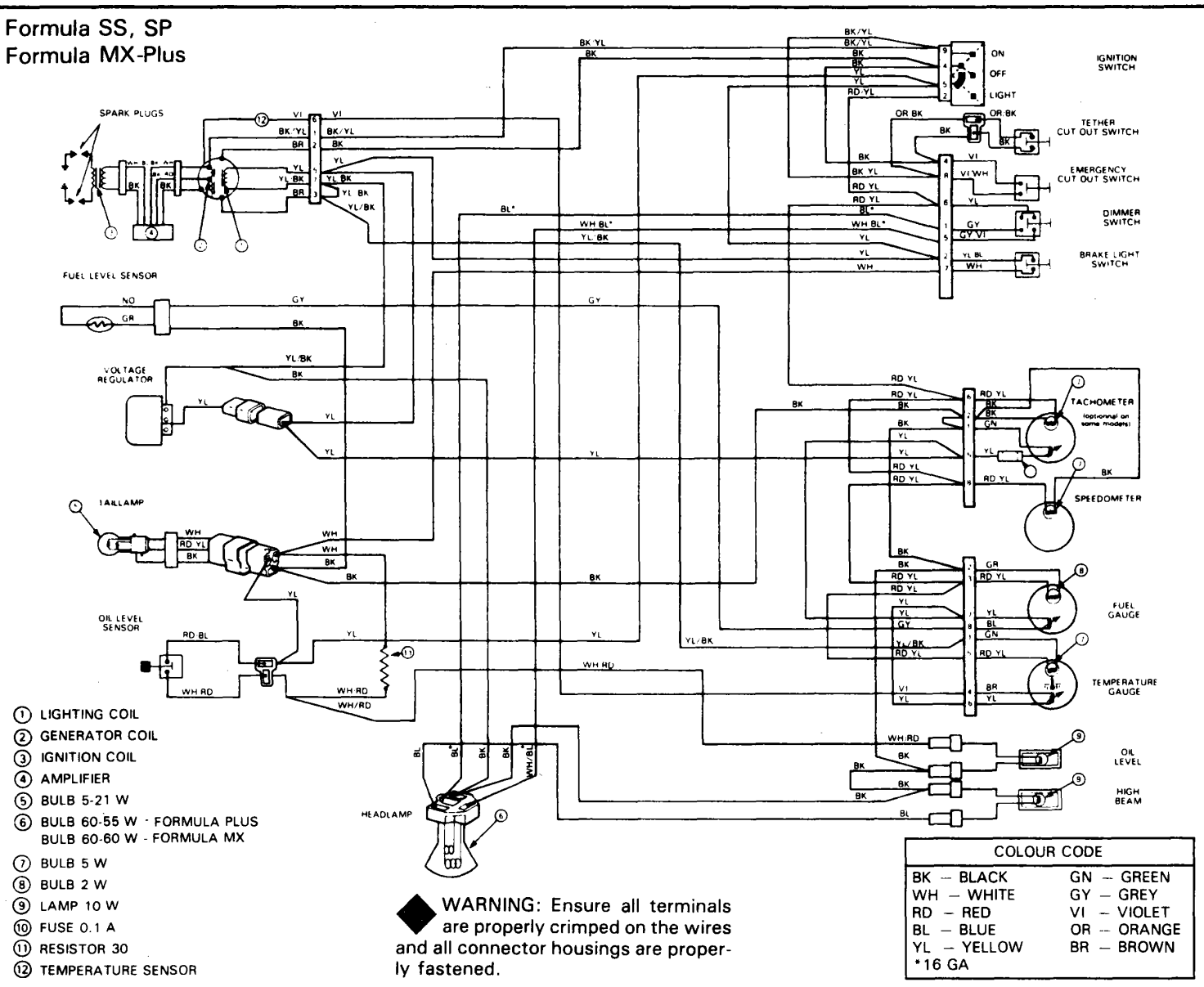

- ① LIGHTING COIL
- ② GENERATOR COIL
- ③ IGNITION COIL
- ④ AMPLIFIER
- ⑤ BULB 5-21 W
- ⑥ BULB 60-55 W - FORMULA PLUS  
BULB 60-60 W - FORMULA MX
- ⑦ BULB 5 W
- ⑧ BULB 2 W
- ⑨ LAMP 10 W
- ⑩ FUSE 0.1 A
- ⑪ RESISTOR 30
- ⑫ TEMPERATURE SENSOR

**WARNING:** Ensure all terminals are properly crimped on the wires and all connector housings are properly fastened.

COLOUR CODE	
BK - BLACK	GN - GREEN
WH - WHITE	GY - GREY
RD - RED	VI - VIOLET
BL - BLUE	OR - ORANGE
YL - YELLOW	BR - BROWN
*16 GA	



Alpine

